

► Simple, Reliable and Accurate

- DN 40 to DN 150
- PFA 10 bar (Allowable operating pressure)
- PMA 16 bar (Allowable Maximum Pressure)

► AQUA 80-910 Function and Installation

The AQUA 80-910 balanced hydraulically operated modulating float valve is installed on the reservoir inlet supply pipe above the maximum water level. As the flow out of the reservoir fluctuates according to changes in demand, the float control proportionally opens or closes the valve keeping the liquid level nearly constant.

On request, various additional devices (option) can be available for completing its operation or mounting ability:

- N1: Upstream surge control (Upstream pressure discharging action in the reservoir).
- N6: Stability of the water level surface (dampening of the wave action).
- N8: Mounting kit for fixing a stilling well against the reservoir wall.

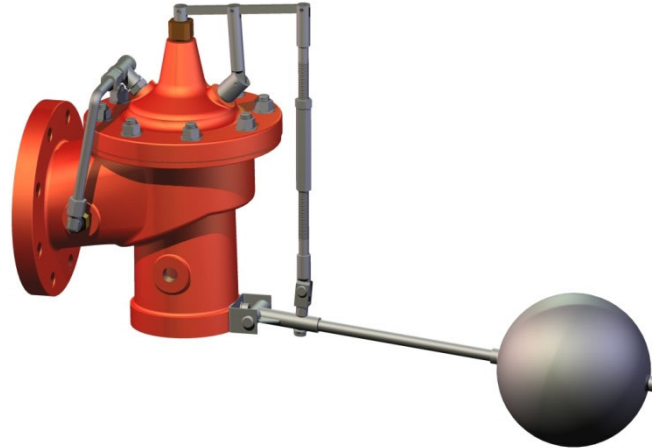

► AQUA 80-910 Dimensions and Process

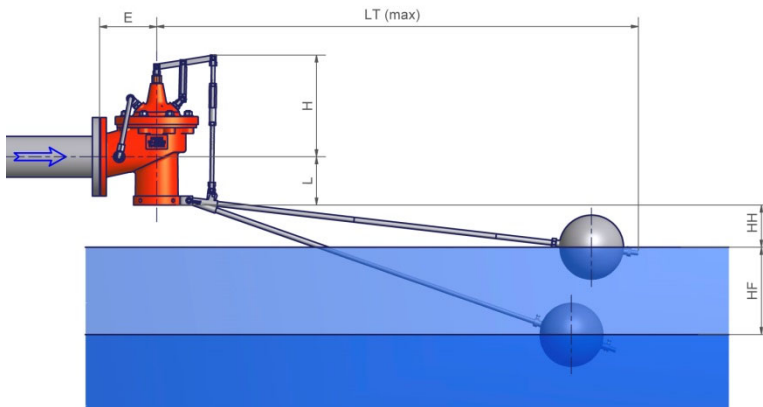

► AQUA 80-910 Materials

- **Casing:** Ductile iron GGG40 EPOXY coated WRAS approved
- **Moving parts:** Stainless Steel 303
- **Renewable seat:** Stainless Steel 316
- **Diaphragm and gaskets:** EPDM
- **Screws & bolts:** Stainless Steel 303
- **Spherical float:** Polished Stainless Steel 316 - Ø 180 mm - 1.5 kg
- **Float arm:** Stainless Steel 303
- **Lever:** Stainless Steel 303

► AQUA 80-910 Technical Specifications

- **Medium:** Water
- **Upstream pressure max.:** 10.0 bar
- **Max. working temperature:** 60°C

Dimensions										
DN (mm)	E (mm)	L (mm)	H max (mm)	LT (mm)	HH (mm)	HF (mm)	Weight (kg)	Cv (l/s) @ 1 bar	Opening (mm)	Q max @ 3 m/s (l/s)
40/50	120	100	280	870	100 - 300	180	13.6	10	10	6
60/65	120	110	280	880	100 - 300	180	14.3	15	15	10
80	140	110	280	890	100 - 300	180	16.4	19	15	15
100	160	135	330	1350	100 - 300	360	30.0	39	22	24
125	170	150	340	1365	100 - 300	480	41.0	52	28	37
150	190	175	410	1380	100 - 300	600	57.0	68	28	53

HH: Adjustable closing level set at closed valve

HF: Opening lift of the float (corresponding to an opening percentage of the valve between 0% and 100%)

► Process

► AQUA 80-910 Height adjustment HH

The high water level can be adjusted from the factory pre set level of 100 mm up to 300 mm by the use of an adjusting nut on the float mechanism. This creates an air gap between valve outlet and top water level to prevent any back siphoning.

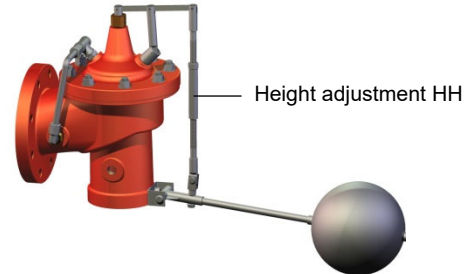

► AQUA 80-910 Balanced hydraulically operated internal assembly

The internal construction of the float valve provides a balanced loading of its diaphragm. The float mechanism proportionally opens or closes the valve accurately as the liquid level changes.

If the dynamic pressure at the inlet of the float valve permanently corresponds to its PFA, it is recommended that an anti-cavitation system «ACS» is fitted (see specific documentation).

If the dynamic pressure at the inlet of the float valve is between 10 bar (PFA) and 16 bar (PMA), it is recommended that a CLA-VAL pressure reducing valve is installed prior to the float valve (see specific documentation).

► AQUA 80-910 Hydraulic Characteristics

The angle pattern design of the float valve provides low flow resistance with a corresponding high Cv flow factor. Valve selection is determined by the internal velocity [v_o] through the valve at the corresponding maximum flow rate [Q_o] which must always be lower than [3 m/s].

Selection of the optimum size [DN] together with the respective pressure drop based on a wide open valve can be made using the graph below.

- (a) Q_o => maximum flow rate.
- (b) ΔP_o => pressure drop of the float valve wide open at Q_o .

Example:

Select an AQUA 80-910 float valve to feed a maximum flow rate of [50 m³/h = 14 l/s]:

- ❶ The ordinate [Q_{max}] cuts the velocity lines at various intersection points.
- ❷ The intersection point located immediately below the horizontal line [3 m/s] determines the size DN 80.
- ❸ The ordinate [Q_{max}] cuts the pressure drop line of the size DN 80 => the intersection point corresponds to the pressure drop ΔP_o at the rate of flow [Q_{max}].

