

TERMINAL SERVICES

***Leading
the Innovation***



CLA-VAL Europe
AUTOMATIC CONTROL VALVES







Leading the Innovation



Cla-Val control valves, refuelling nozzles, couplers and other ground fuelling equipment play a vital role in fuel handling systems for both civilian and military aviation.

Applications include control of fuel at receiving facilities, storage tanks, fuel/water separation stations, distribution/circulation systems and mobile refuellers and aircraft hot refuelling.

WWW.CLA-VAL.CH

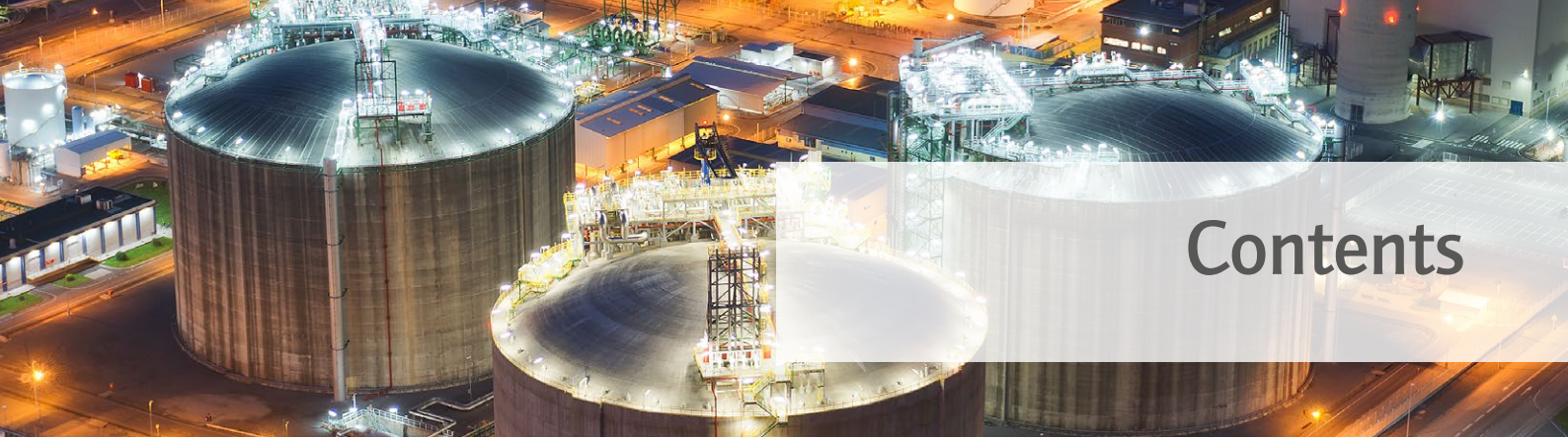

Contents

Company Overview

8-10

Marketing Sheets & data Sheets

Main valve

- CLA-VAL 100-34 - Hytrol Valve 12-13

Rate of flow control valve

- CLA-VAL 40-32 - Rate of flow control valve 14-15
- CLA-VAL 40-36 - Rate of flow control and fuel shut-off valve 16-17
- CLA-VAL CFF18T-H2 - Flanged float control for fuel-water separators 18-19
- CLA-VAL CFF21 - Flanged float control for fuel-water separators 20-21
- CLA-VAL 40-30 - Rate of flow control valve 22-23
- CLA-VAL 43-37 - Combination rate of flow and solenoid shut-off valve 24-25

Back pressure control valve

- CLA-VAL 50-48 - Back pressure control valve 26-27

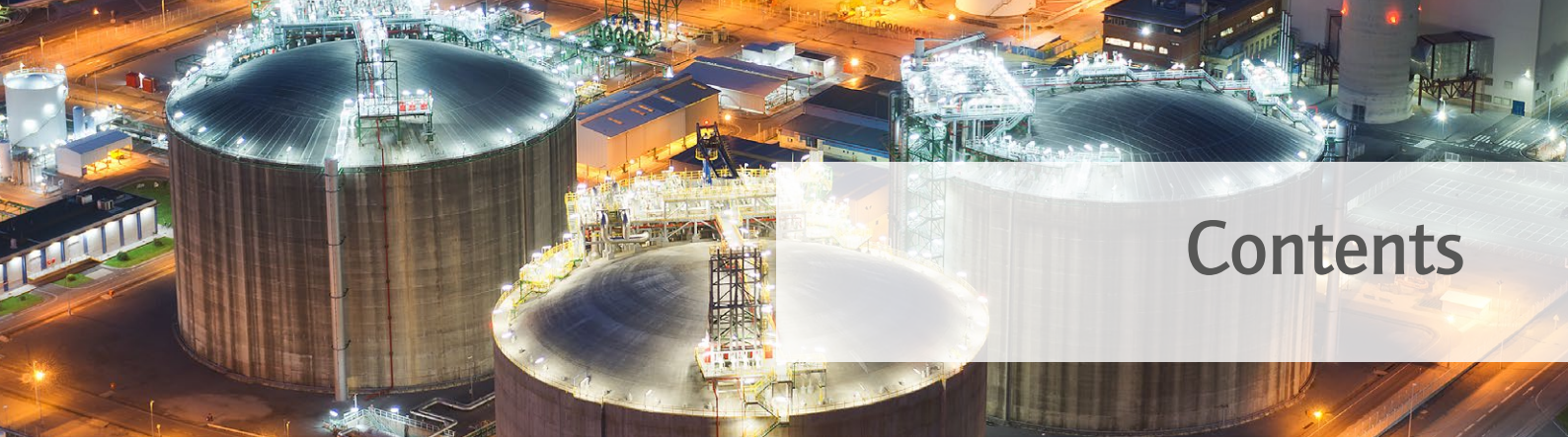

Contents

Level control valve

- CLA-VAL 129-26 – High level shut-off valve 28-29

Truck loading valve

- CLA-VAL 131-CP – Electronic interface control valve 30-31
- CLA-VAL 72-401 – Two stage set stop valve 32

Terms and Conditions of Sale and Warranty 44-46

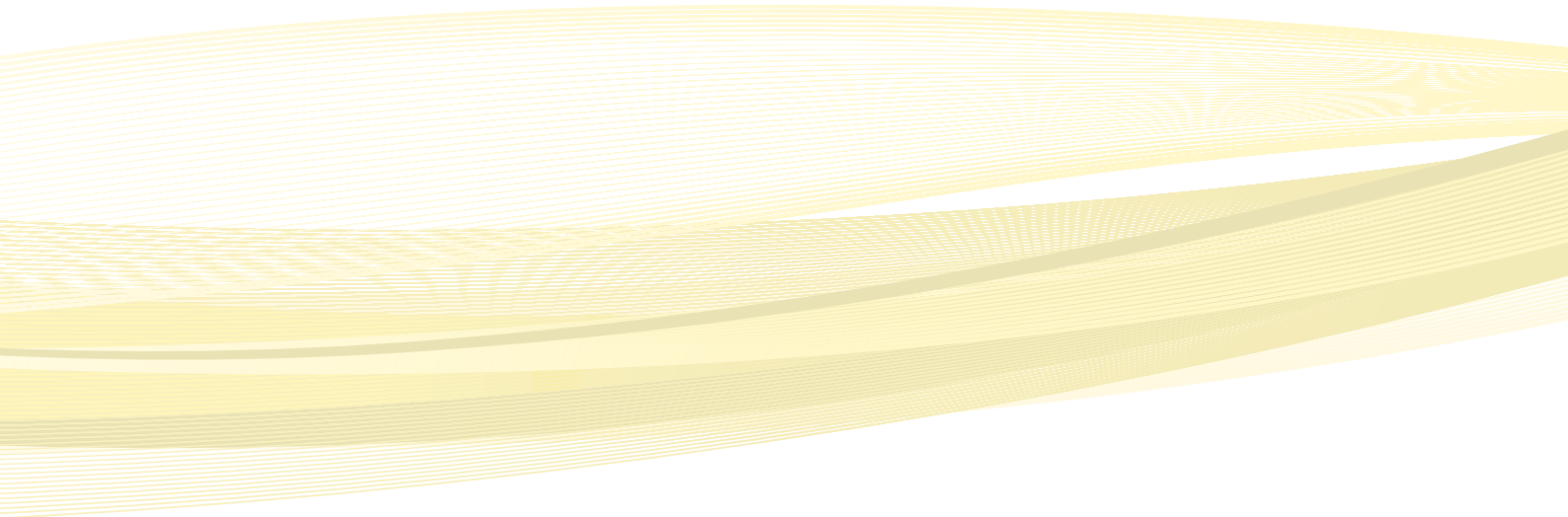

Notes

A series of horizontal dotted lines for writing notes, spanning the width of the page.

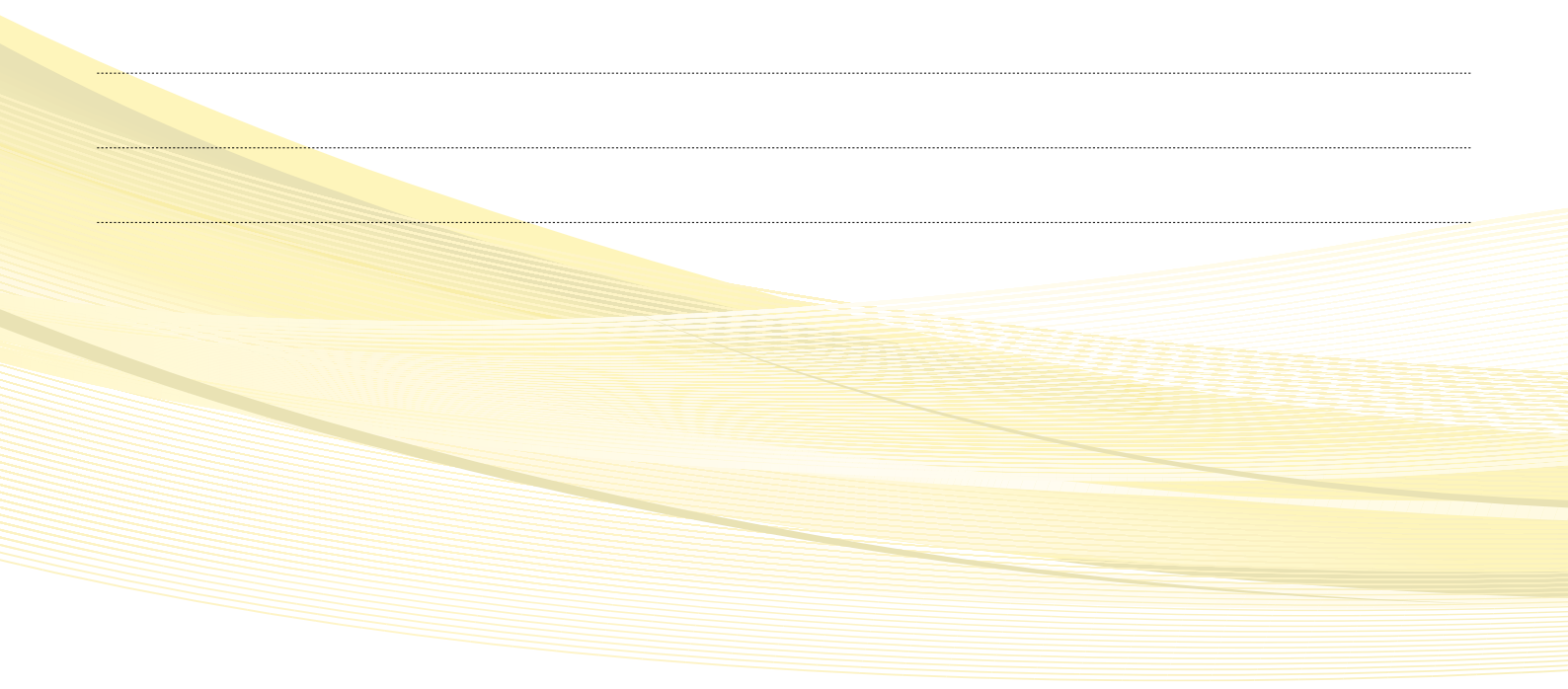



Company Overview



Company Overview

Since 1936, CLA-VAL has been a leading manufacturer of automatic control valves, serving waterworks, industrial, fire protection, aviation fuelling and marine customers throughout the world. Our commitment to excellence and continuous improvement shows in each valve we produce and in the many new products we introduce to the marketplace each year.

CLA-VAL is a global company with headquarters and a 20-acre manufacturing/foundry complex in Newport Beach, California, in addition to production facilities in Canada, Switzerland, France and the United Kingdom.

CLA-VAL's long history of manufacturing and industry excellence also enables us to provide the industry's most comprehensive program of hands-on, personalized technical/product training at our in-house training facilities in the US, Canada, Switzerland, the UK and France.

CLA-VAL Automatic Control Valves are renowned for their quality and superior performance. The company is also known for consistently excellent customer service as well as innovation, specifically related to products that help to conserve water and energy.

Our company website at www.cla-val.ch or www.cla-val.com offers a comprehensive overview of our extensive product line and field service capabilities as well as access to hundreds of technical documents.

Onsite foundries

- Soundcast Company - Sand casting foundry
- Griswold Castings - Investment foundry, lost wax process

By having two on-site foundries, CLA-VAL is able to provide castings in over 50 different alloys, making our product offering one of the most extensive in the valve industry. It also allows us to respond more quickly to our customers' unique requirements. A small sample of the many materials our foundries produce include the following alloys:

- Ductile Iron
- Cast Steel
- Stainless Steel
- Monel
- Nickel Aluminum Bronze
- Naval Bronze
- Super Austenitic Stainless Steel
- Super Duplex Stainless Steel
- Titanium
- And many more



Inventor and producer of the hytrol control valve

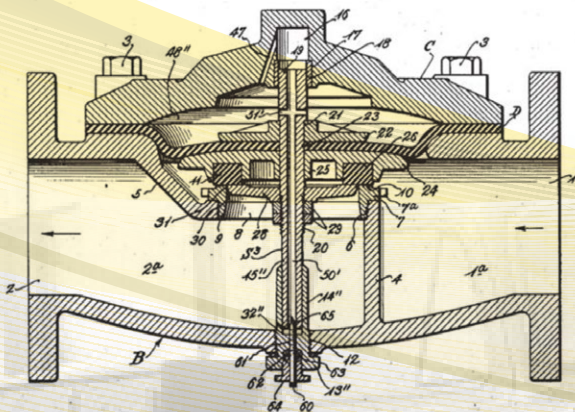

Original Filed May 1, 1940

CLA-VAL CO.

Automatic Control



Company Overview

Global manufacturing facilities overview

- State-of-the art manufacturing equipment:
Multiple Mazak Multi-Task Milling & Turning; CNC Lathe & Milling machines
Many more manual machine cells including Vertical Turret Lathes
- Large inventory of products on the shelf and ready to ship to meet customers' immediate needs



Product range

CLA-VAL offers an extensive range of products from basic hydraulic valves to SCADA compatible electronic control valves to perform the following functions in waterworks, water savings, industrial, fire protection, marine and aviation fuelling applications.

Pressure
Pressure Relief
Pressure Management
Pressure Increasing
Cavitation Prevention
Surge Control
Metering

Reducing Pump Control
Rate of Flow/Flow Limiting
Level Control
Tank Filling
Blending
Flushing
Reclaimed Water

Suppression Deluge
Air Release
Vacuum Breaking
Flow Reversal Prevention
Fuelling High-Level Shut-Off
Fuelling Back Pressure Control
Contamination Monitoring



From the Smallest: 3/8 inch



To the Largest: 56 inch (DN 1400)



Company Overview

Training capabilities and facilities

CLA-VAL offers personalized technical assistance, maintenance support, and end-user training programs, including comprehensive engineering, service training and application seminars at the factory and on-site. This, in turn, helps our customers to achieve optimal performance of CLA-VAL products during start-up, after installation and through decades of reliable trouble-free service.

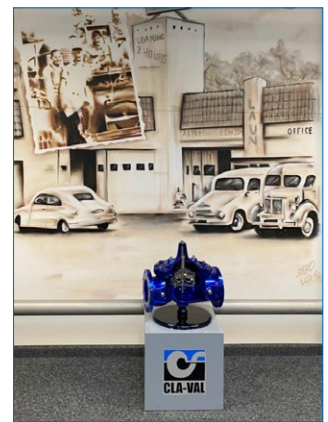
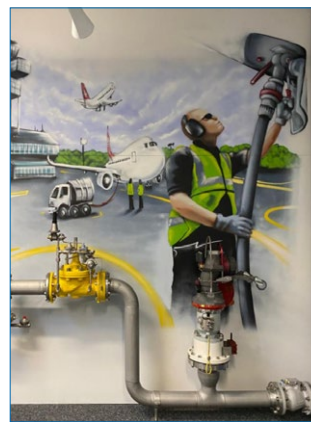

Approvals and certifications

CLA-VAL's fuelling, waterworks and fire protection products meet all applicable standards and specifications prescribed by military and civil industry organizations such as AWWA, FDA, NSF, UL, and FM International. Along with ISO 9001 certifications for our production facilities in Switzerland and the UK, and ISO 9002 for our manufacturing facility in Canada, CLA-VAL also currently holds many other certifications, listings and approvals in North America and around the world :

- American Petroleum Institute
- Department of the Navy
- Soundcast Foundry: TUV Approval
- Underwriter's Laboratory Canada (ULC)
- Underwriter's Laboratory (UL)
- Factory Mutual (FM)
- National Sanitary Foundation
- American Society of Sanitary Engineers (ASSE)
- Canadian Standards Association (CSA)
- Water Regulations Advisory Scheme (WRAS)
- International Organization for Standardization (ISO)
- Attestation de conformité sanitaire (ACS)
- Association Suisse Eau & Gaz (SVWG)
- Assemblée Plénière des Sociétés d'Assurance Dommage (APSAD)
- Austrian Association for Gas and Water Industries (OVGW)
- NYC Material and Equipment Acceptance Division (MEA)
- Public Utilities Board Singapore (PUB)
- Technical Standards & Safety Authority (TSSA)





Marketing Sheets & Data Sheets



CLA-VAL 100-34

Hytrol valve



- **Accurate Repeatable High Level Shut-off**
- **"Fail-Safe" Construction**
- **No Packing Glands Assure Leak-Proof Service**

The Cla-Val Model 100-34 Hytrol Valve is used as the basic unit in almost all Cla-Val automatic control valves for petroleum applications. The 100-34 is a hydraulically-operated, diaphragm actuated, globe or angle pattern valve. It is available in various materials and full range of sizes. It consists of three major components: body, diaphragm assembly and cover. The diaphragm assembly is the only moving part. The rugged simplicity of design and packless construction assure a long life of dependable, trouble-free operation. Should the diaphragm become damaged the valve will close tight, providing "fail safe" operation. The 100-34 Hytrol Valve is used in many types of piping system requiring remote control, pressure regulation, solenoid operation, rate of flow control, liquid level control, or check valve operation.

Principle of Operation

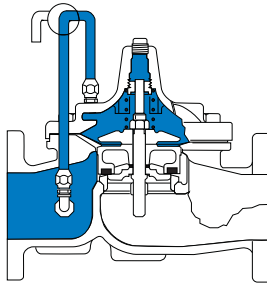

Tight Closing Operation

When pressure from the valve inlet (or an equivalent independent operating pressure) is applied to the diaphragm chamber, the valve closes drip-tight.

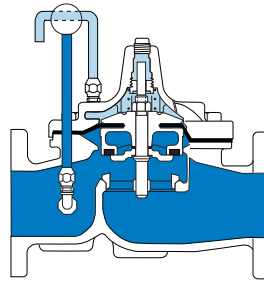

Full Open Operation

When pressure in the diaphragm chamber is relieved to zone of lower pressure under the valve. Flow in either direction is permitted.

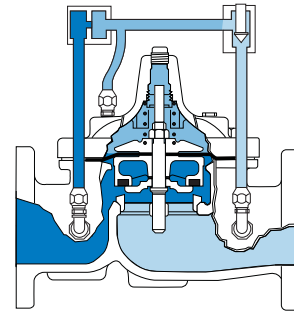

Modulating Action

The main valve modulates when diaphragm chamber pressure is held at an intermediate point between inlet and discharge pressure changes. Pressure above the diaphragm is varied, allowing the valve to modulate and compensate for the changes.

Specifications

Pressure Ratings (Recommended Maximum Pressure - psi)

Valve Body & Cover		Pressure Class				
		Flanged			Grooved	Threaded
Grade	Material	ANSI Standards*	150 Class	300 Class	300 Class	End‡ Details
ASTM A536	Ductile Iron	B16.42	250	400	400	400
ASTM A216-WCB	Cast Steel	B16.5	285	400	400	400
ASTM B62	Bronze	B16.24	225	400	400	400
356-T6	Aluminum	B16.3	275	---	---	---

Sizes: *Globe:* 1 1/2" - 16" flanged
Angle: 2" - 16" flanged

Valve trim:

Bronze ASTM B61
Cast Stainless Steel 300 Series

Rubber parts:

Buna-N® Synthetic Rubber
Viton

Other Materials

Available on Special Order

Note: * ANSI standards are for flange dimensions only. Flanged valves are available faced but not drilled.

‡ End Details machined to ANSI B2.1 specifications. • **Valves for higher pressure are available; consult factory for details**



CLA-VAL 100-34

Hytrol valve

SIZE	1 1/2	2	2 1/2	3	4	6	8	10	12	14	16
A 125 & 150 ANSI	8.50	9.38	11.00	12.00	15.00	20.00	25.38	29.75	34.00	39.00	41.38
AA 250 & 300 ANSI	9.00	10.00	11.62	13.25	15.62	21.00	26.38	31.12	35.50	40.50	43.50
B DIAMETER	5.62	6.62	8.00	9.12	11.50	15.75	20.00	23.62	28.00	32.75	35.50
C MAX.	5.50	6.50	7.56	8.19	10.62	13.38	16.00	17.12	20.88	24.19	25.00
D	1.12	1.50	1.69	2.06	3.19	4.31	5.31	9.25	10.75	12.62	15.50
E 125 & 150 ANSI	4.75	5.00	6.00	7.50	10.00	12.75	14.88	17.00	19.50	20.81	
EE 250 & 150 ANSI	5.00	5.88	6.38	7.88	10.50	13.25	15.56	17.75	20.25	21.62	
F 125 & 150 ANSI	3.25	4.00	4.00	5.00	6.00	8.00	8.62	13.75	14.88	15.69	
FF 250 & 300 ANSI	3.50	4.31	4.38	5.31	6.50	8.50	9.31	14.50	15.62	16.50	

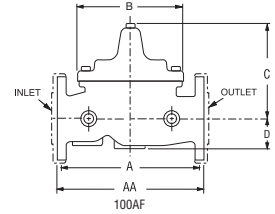

C_V Factor

VALVE SIZE	1 1/2	2	2 1/2	3	4	6	8	10	12
100-34 GLOBE PATTERN	26	49	80	107	200	440	771	1151	1600
100-34 ANGLE PATTERN	30	62	100	137					

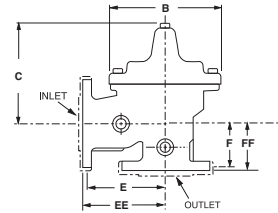

C_V factor is defined as the number of gallons per minute of water at 60°F that will flow with a 1 psi pressure differential across the valve.

Purchase Specifications

The valve shall be hydraulically-operated, diaphragm-actuated, globe or angle pattern valve. It shall contain a resilient, synthetic rubber disc, having a rectangular cross section, contained on three and on-half sides by a disc retainer and disc guide, forming a tight seal against a single renewable seat. The valve stem shall be guided at both ends by a bearing in the valve cover and an integral bearing in the valve seat. The diaphragm assembly shall be the only moving part and shall form a sealed chamber in the upper portion of the valve, separating operating pressure from line pressure. The diaphragm consist of nylon fabric

bonded with synthetic rubber and shall not be used as a seating surface. Packing glands and/or stuffing boxes are not permitted and there shall be no pistons operating the valve. All necessary repairs shall be possible without removing the valve from the line. If the diaphragm becomes damaged the valve shall close tight. This valve shall be a Model 100-34 (globe pattern or angle pattern) Hytrol Valve as manufactured by Cla-Val. Newport Beach, California.

Specify When Ordering

1. Size
2. Model 100-34 Globe or Angle
3. Pressure Class
4. Temperature and fluid to be handled
5. Static and flowing line pressure
6. Operating fluid and pressure (if other than line pressure)
7. Body and trim materials
8. End details

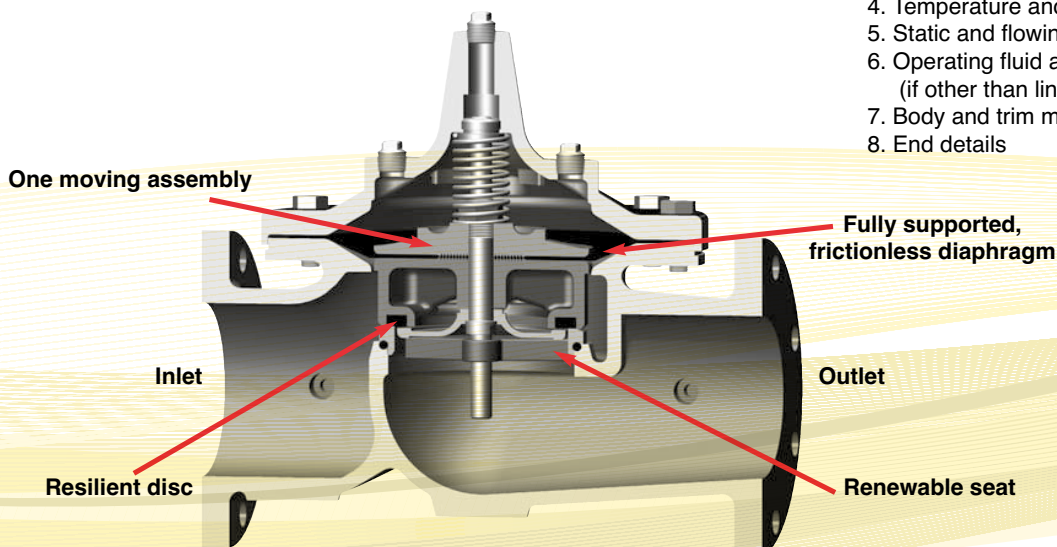

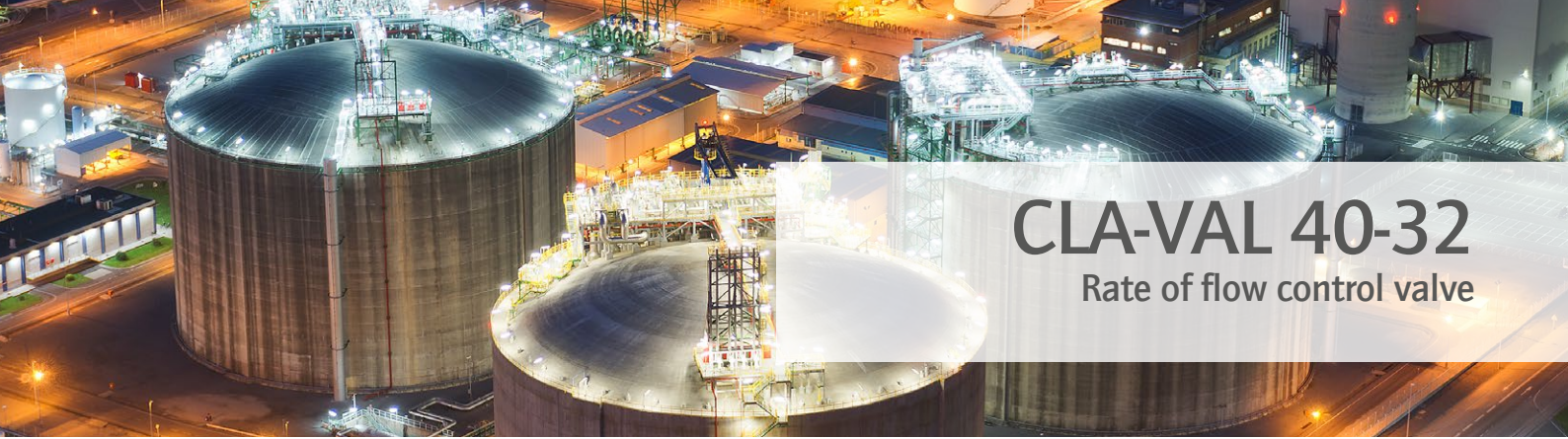

CLA-VAL 40-32

Rate of flow control valve

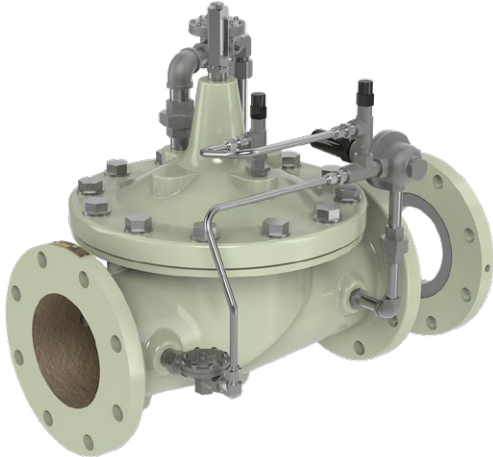

- **Accurately Limits Flow Rate**
- **Protects Pumps against reverse flow**
- **Surge-Free Operation**
- **Adjustable opening & closing rates**
- **Fail Safe operation**
- **Easy to Maintain**

The Cla-Val Model 40-32 Rate of Flow Non-Surge Check Valve is a hydraulically operated, pilot controlled, diaphragm actuated control valve that limits flow to a preselected maximum rate, regardless of changing line pressure. The pilot control responds to the differential pressure produced across an orifice plate installed downstream of the valve. Accurate control is assured as very small changes in the controlling differential pressure produce immediate corrective action of the main valve. The orifice bore is factory sized based on flow rate to ensure proper control valve performance. Flow rate adjustments can be made by turning an adjusting screw on the pilot control. The integrated check feature protects upstream equipment like pumps by admitting downstream pressure into the main valve cover chamber, closing the main valve upon pressure reversal.

Purchase Specifications

Pilot Control System

The 40-32 Rate of Flow Non-Surge Check Valve shall limit flow to a preselected maximum rate regardless of changing line pressure. The hydraulic control valve pilot system shall consist of a direct acting diaphragm valve designed to close when the controlling differential exceeds the adjustable spring setting. The pilot control is normally held open by the force of the compression on the spring above the diaphragm and it closes when the pressure acting on the underside of the diaphragm exceeds the spring setting. The pilot control system shall contain a fixed orifice. No variable orifices shall be permitted. A flanged orifice plate assembly shall be included and mounted to the downstream (outlet) flange. Optional pilot system features shall include (A) Flow Clean Strainer, (B) CK2 Isolation Ball Valves, (C) CV Closing Speed Control, (G) Check Feature, (Q) Quick Connect Assembly, (S) CV Opening Speed Control, (T) 55F Thermal Pressure Relief Control, (Y) X43 "Y" Strainer.

Main Valve

The valve shall be hydraulically operated, single diaphragm-actuated, globe or angle pattern. It shall contain a resilient, synthetic disc with a rectangular cross-section contained on three and one-half sides by a disc retainer and forming a tight seal against a single removable seat insert. The diaphragm assembly shall be the only moving part and shall form a sealed chamber in the upper portion of the valve, separating operating pressure from line pressure. The diaphragm consists of nylon fabric bonded with synthetic rubber and shall not be used as the seating surface. The valve stem shall be fully guided at both ends by a bearing in the valve cover and an integral bearing in the valve seat. To insure proper alignment of the valve stem, the valve body and cover shall be machined with a locating lip. No "pinned" covers to the valve body shall be permitted. Packing glands and/or stuffing boxes are not permitted and there shall be no pistons operating the main valve or pilot controls. All necessary repairs and/or modifications other than replacement of the main valve body shall be possible without removing the valve from the pipeline. The valve manufacturer shall warrant the valve to be free of defects in material and workmanship for a period of three years from date of shipment, provided the valve is installed and used in accordance with all applicable instructions.

Specifications

Sizes

Globe: 1 1/2" - 16" flanged
 Angle: 2" - 16" flanged

End Details

Flanged:
 Cast Aluminum, 150 ANSI B16.1
 Cast Bronze, 150 & 300 ANSI B16.24
 Ductile Iron, 150 & 300 ANSI B16.42
 Cast Steel, 150 & 300 ANSI B16.5

Temperature Range

Light Petroleum Product -40° to+140°F

Pressure Ratings

150 class 175-PSI Max.
 150 class 275-PSI Max.
 250 class 300-PSI Max.
 300 class 400-PSI Max.

Material

Body & cover:
 Cast Aluminum 356-T6
 Cast Bronze ASTM B62
 Ductile Iron ASTM A-536
 Cast Stainless Steel 303
 Cast Steel ASTM A216-WCB

Valve trim:

Bronze ASTM B61
 Stainless Steel 303

Rubber parts:

Buna-N® Synthetic Rubber
 Viton

Other Materials

Available on Special Order

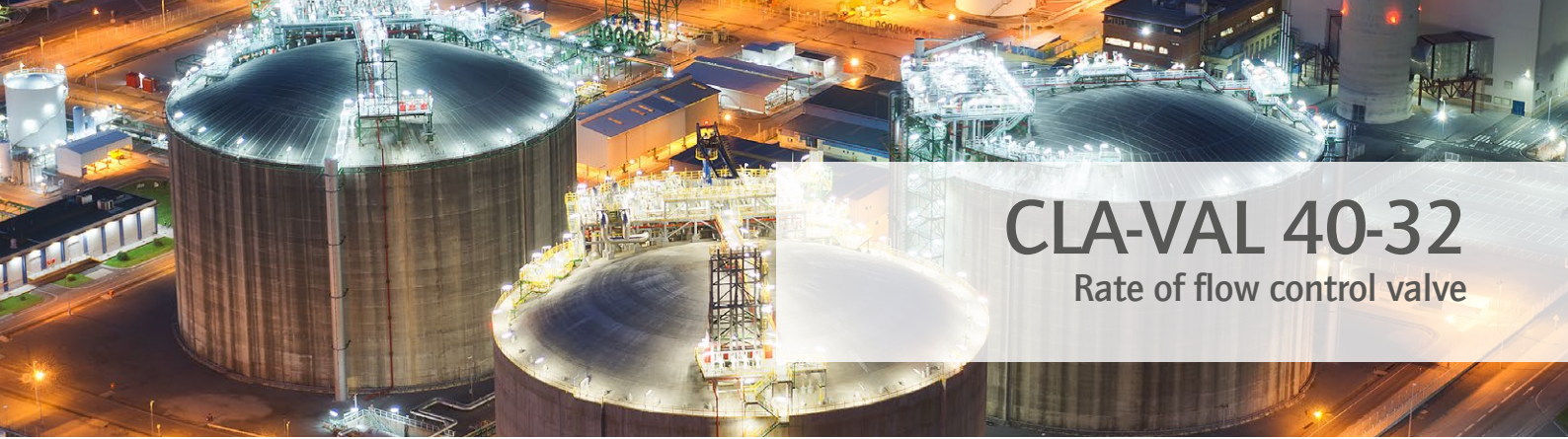

CLA-VAL 40-32

Rate of flow control valve

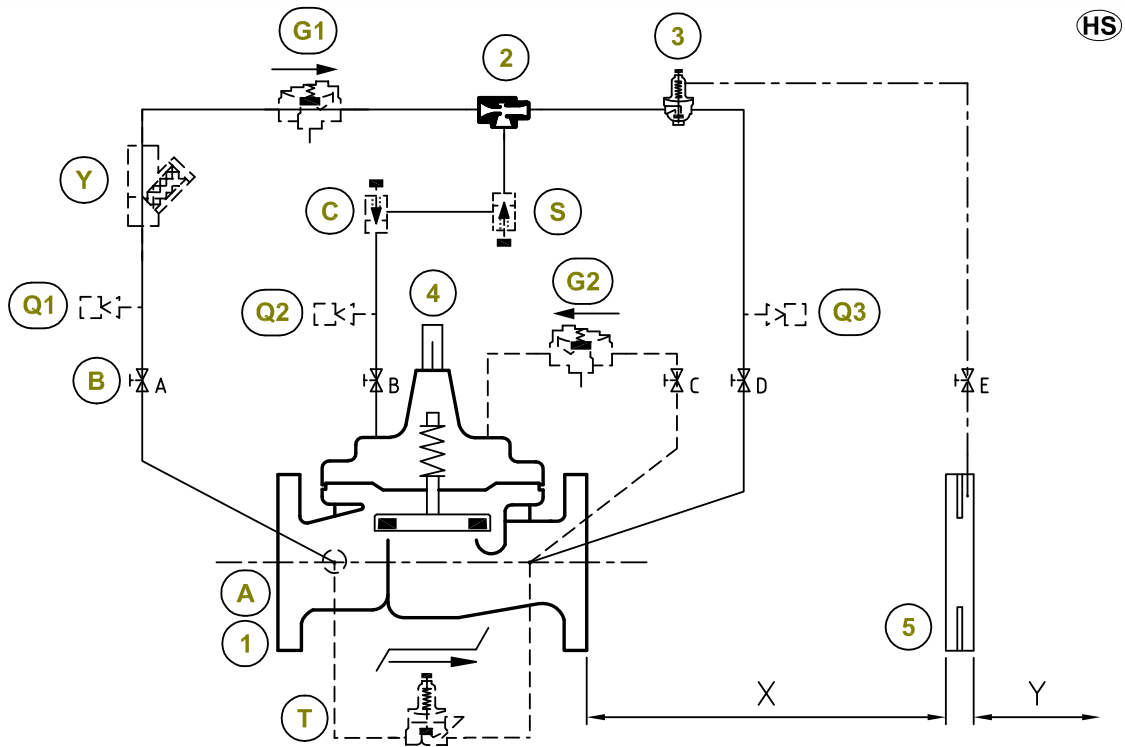

STANDARD EQUIPMENT

No	Description	Qty	Type
1	MAIN VALVE HYTROL AE/GE/NGE	1	100-34/KR *
2	EJECTOR	1	X47-A
3	DIFFERENTIAL PRESSURE CONTROL	1	CDHS-18
4	VALVE POSITION INDICATOR	1	X101
5	ORIFICE PLATE ASSEMBLY	1	X52-A

OPTIONAL FEATURES

No	Description	Qty	Type
A	FLOW CLEAN STRAINER	1	X46A
B	ISOLATION BALL VALVE	5	RB-117
C	ONE-WAY FLOW CONTROL (CLOSING SPEED)	1	CV
G	CHECK VALVE	2	81-01
Q	QUICK CONNECT ASSEMBLY	3	-
S	ONE-WAY FLOW CONTROL (OPENING SPEED)	1	CV
T	PRESSURE RELIEF VALVE	1	55F **
Y	STRAINER	1	X43

NOTES

AE/GE : DN 32 - DN 400 / NGE : DN 50 - DN 600

(#) = According to valve size this feature type could change

NOTE :

Orifice plate assembly X52-A (5) may be fixed directly to the main valve outlet flange, however, better control is obtained, if it is mounted according to the following recommendation :

distance X = 5x pipe diameter, distance Y = 3x pipe diameter.

* Main Valve Option : 9HS999

OPTIONAL FEATURES : _____

NOT FURNISHED BY CLA-VAL : _____



CLA-VAL 40-36

Rate of flow control and fuel shut-off valve



- **Accurately Limits Flow Rate**
- **Remote Shutoff Feature**
- **Protects Filter Separators Against Reverse Flow**
- **Adjustable opening & closing rates**
- **Fail Safe operation**
- **Easy to Maintain**

The Cla-Val Model 40-36 Rate of Flow and Fuel Shutoff Check Valve is a hydraulically operated, pilot controlled, diaphragm actuated control valve that limits flow to a preselected maximum rate, regardless of changing line pressure. The pilot control responds to the differential pressure produced across an orifice plate installed downstream of the valve. Accurate control is assured as very small changes in the controlling differential pressure produce immediate corrective action of the main valve. The orifice bore is factory sized based on flow rate to ensure proper control valve performance. Flow rate adjustments can be made by turning an adjusting screw on the pilot control. The fuel shutoff feature closes the main valve when remote pressure from a Cla-Val Model CFF18T-H2 or CFF21-H2 flanged float control is admitted into the cover of an auxiliary Hytrol. The integrated check feature protects upstream equipment like filter separators by admitting downstream pressure into the main valve cover chamber, closing the main valve upon pressure reversal.

Purchase Specifications

Pilot Control System

The 40-36 Rate of Flow Non-Surge Check Valve shall limit flow to a preselected maximum rate regardless of changing line pressure. The hydraulic control valve pilot system shall consist of a direct acting diaphragm valve designed to close when the controlling differential exceeds the adjustable spring setting. The pilot control is normally held open by the force of the compression on the spring above the diaphragm and it closes when the pressure acting on the underside of the diaphragm exceeds the spring setting. The pilot control system shall contain a fixed orifice. No variable orifices shall be permitted. A flanged orifice plate assembly shall be included and mounted to the downstream (outlet) flange. The fuel shutoff feature shall close the main valve when remote pressure is introduced into the cover of an auxiliary Hytrol incorporated into the pilot control system. Optional pilot system features shall include (A) Flow Clean Strainer, (B) CK2 Isolation Ball Valves, (C) CV Closing Speed Control, (G) Check Feature, (Q) Quick Connect Assembly, (S) CV Opening Speed Control, (T) 55F Thermal Pressure Relief Control, (Y) X43 "Y" Strainer.

Main Valve

The valve shall be hydraulically operated, single diaphragm-actuated, globe or angle pattern. It shall contain a resilient, synthetic disc with a rectangular cross-section contained on three and one-half sides by a disc retainer and forming a tight seal against a single removable seat insert. The diaphragm assembly shall be the only moving part and shall form a sealed chamber in the upper portion of the valve, separating operating pressure from line pressure. The diaphragm consists of nylon fabric bonded with synthetic rubber and shall not be used as the seating surface. The valve stem shall be fully guided at both ends by a bearing in the valve cover and an integral bearing in the valve seat. To insure proper alignment of the valve stem, the valve body and cover shall be machined with a locating lip. No "pinned" covers to the valve body shall be permitted. Packing glands and/or stuffing boxes are not permitted and there shall be no pistons operating the main valve or pilot controls. All necessary repairs and/or modifications other than replacement of the main valve body shall be possible without removing the valve from the pipeline. The valve manufacturer shall warrant the valve to be free of defects in material and workmanship for a period of three years from date of shipment, provided the valve is installed and used in accordance with all applicable instructions.

Specifications

Sizes

Globe: 1 1/2" - 16" flanged
Angle: 2" - 16" flanged

End Details

Flanged:
Cast Aluminum, 150 ANSI B16.1
Cast Bronze, 150 & 300 ANSI B16.24
Ductile Iron, 150 & 300 ANSI B16.42
Cast Steel, 150 & 300 ANSI B16.5

Temperature Range

Light Petroleum Product -40° to +140°F

Pressure Ratings

150 class 175-PSI Max.
150 class 275-PSI Max.
250 class 300-PSI Max.
300 class 400-PSI Max.

Material

Body & cover:
Cast Aluminum 356-T6
Cast Bronze ASTM B62
Ductile Iron ASTM A-536
Cast Stainless Steel 303
Cast Steel ASTM A216-WCB

Valve trim:

Bronze ASTM B61
Stainless Steel 303

Rubber parts:

Buna-N® Synthetic Rubber
Viton

Other Materials

Available on Special Order



CLA-VAL 40-36

Rate of flow control and fuel shut-off valve

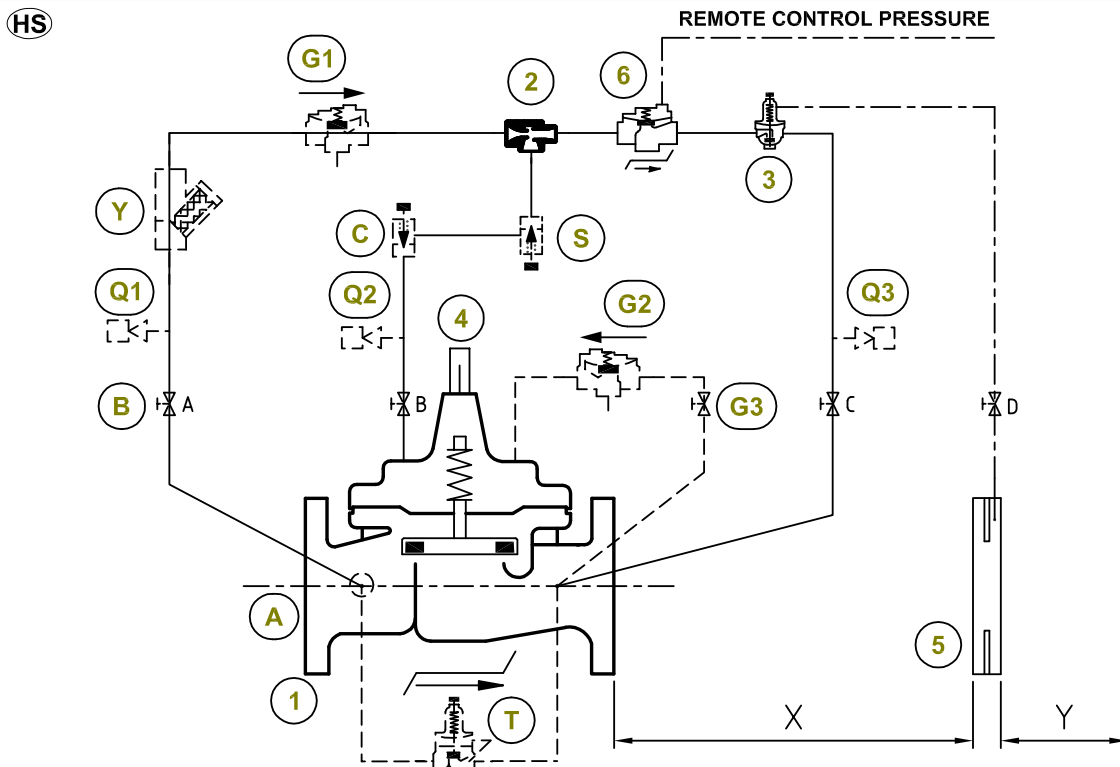

STANDARD EQUIPMENT			
No	Description	Qty	Type
1	MAIN VALVE HYTROL AE/GE/NGE	1	100-34/KR *
2	EJECTOR	1	X47-A
3	DIFFERENTIAL PRESSURE CONTROL	1	CDHS-18
4	VALVE POSITION INDICATOR	1	X101
5	ORIFICE PLATE ASSEMBLY	1	X52-A
6	AUXILIARY VALVE HYTROL	1	100-KHR

OPTIONAL FEATURES			
No	Description	Qty	Type
A	FLOW CLEAN STRAINER	1	X46A
B	ISOLATION BALL VALVE	5	RB-117
C	ONE-WAY FLOW CONTROL (CLOSING SPEED)	1	CV
G	CHECK VALVE	2	81-01
Q	QUICK CONNECT ASSEMBLY	3	-
S	ONE-WAY FLOW CONTROL (OPENING SPEED)	1	CV
T	PRESSURE RELIEF VALVE	1	55F **
Y	STRAINER	1	X43

NOTES	
AE/GE : DN 32 - DN 400 / NGE : DN 50 - DN 600	OPTIONAL FEATURES : _____
(#) = According to valve size this feature type could change	NOT FURNISHED BY CLA-VAL : _____
* Main Valve Option: 9HS999	
** 55F (Option T) is used only with option (G)	
Orifice plate assembly X52-A (5) may be fixed directly to the main valve outlet flange, however, better control is obtained, if it is mounted according to the following recommendation : distance X = 5x pipe diameter, distance Y = 3x pipe diameter.	



CFF18T-H2

Flanged float control for fuel-water separators

- Fully automatic operation
- Conforms to rigid military specifications
- No packing glands; requires no lubrication
- Compact and simple to install
- No mechanical linkage or electrical connections
- No exposed moving parts or stuffing boxes



The Cla-Val Model CFF18T-H2 Fuel-Water Separator Control automatically operates the fuel discharge valve and the water drain valve of fuel-water filter separators. It is mounted to a flange on the side of the separator vessel in the sump. The float responds to changes in level of the interface surface of the water and fuel inside the sump area. The pilot valve is a precision-lapped rotary disc, plate type valve. The CFF18T-H2 Control automatically performs the following functions:

1. Opens the water drain valve (Model 100AF) to remove accumulated water that exceeds the safe level in sump area.
2. Closes the fuel discharge valve (Model 413-01 or 40-28 AGS) should the water level rise to the upper float level. The water drain valve remains open.
3. Re-opens the fuel discharge valve when the water in the sump lowers to a safe level.
4. Closes the water drain valve when the level reaches a low point in the sump.
5. Provides easy manual testing of fuel-water separator control function with simple plunger-type mechanism spring loaded to return to normal operating position.

The CFF18T-H2 Control is used with aviation gasoline, jet fuels, motor fuels, diesel, solvents and other petroleum products. This control has a variable pressure rating depending on lever arm length and is suitable for handling liquids with a specific gravity of 0.90 or less.

DIMENSIONS (In Inches)

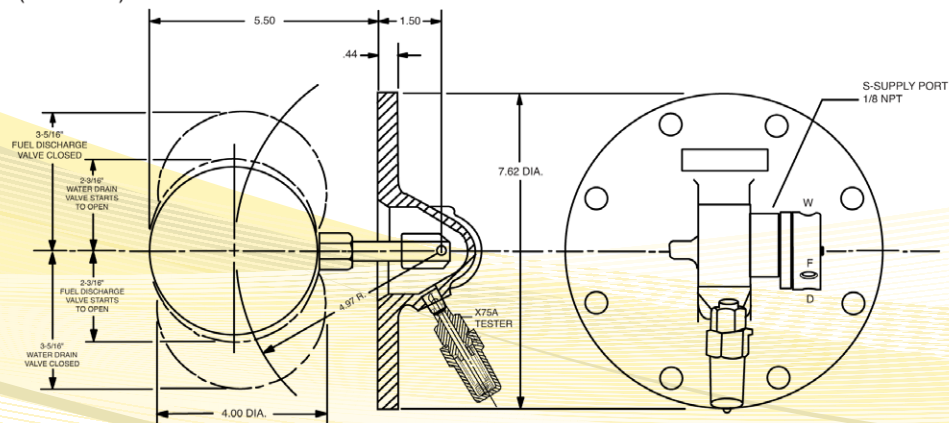



CFF18T-H2

Flanged float control for fuel-water separators

WITH WATER DRAIN VALVE, WITH PRODUCT RECOVERY TANK

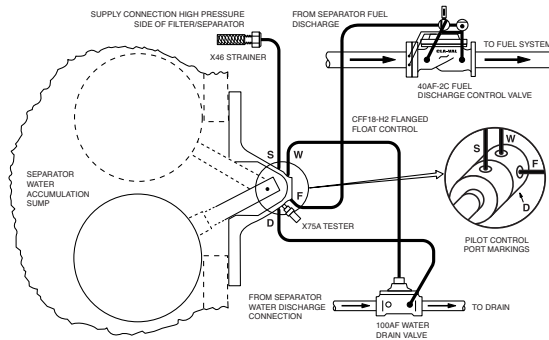

WITHOUT WATER DRAIN VALVE, WITH PRODUCT RECOVERY TANK

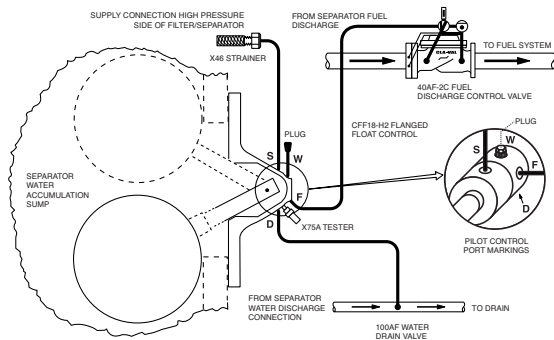

WITHOUT WATER DRAIN VALVE OR PRODUCT RECOVERY TANK

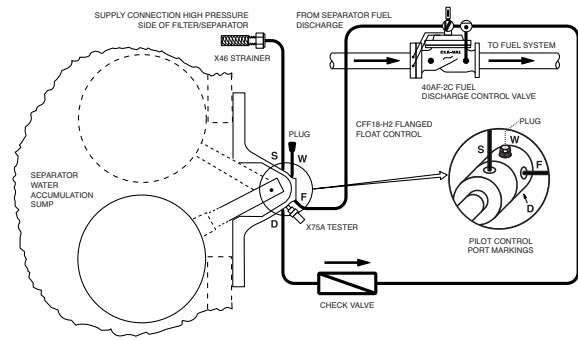

FLOAT POSITION	WATER DRAIN VALVE	FUEL DISCHARGE VALVE
DOWN	CLOSED	OPEN
CENTER	OPEN	OPEN
UP	OPEN	CLOSED

SPECIFICATIONS

MILITARY

MIL-F-254, MIL-F-15618 and MIL-F-27629B (USAF)

**TEMPERATURE RANGE
FLUIDS**

Water and light petroleum products, MIL-F-5572, MIL-J-5624 and MIL-F-5616

**PRESSURE RATING
MATERIALS**

225 psi maximum
Flange:
Stainless Steel ASTM A296
Aluminum 356T6

Pilot Housing:
Stainless Steel Type 303
ASTM A296

Pilot Valve:
Stainless Steel Bar AISI 303

Float and Float Arm:
Stainless Steel AISI 303
1/8" N.P.T.

**CONTROL PORT
CONNECTION SIZE**

Note: Available without X75A Tester as Model CFF18-H2.

PURCHASE SPECIFICATIONS

This control shall be specifically designed to respond to changes in level of the interface surface of the water and fuel inside the water sump of fuel-water separator and shall operate the diaphragm actuated water drain valve and fuel discharge valve. The actuating fluids on the diaphragms of both the water drain valve and the fuel discharge valve shall be relieved through the pilot valve to the water drain valve.

The float control shall consist of a pilot valve mounting flange and float assembly. The float shall be designed to sink in fuel and float in water. The pilot shall be a precision-lapped, rotary disc plate type valve. Porting arrangement shall permit control of a water drain valve and a fuel discharge valve. A manual plunger-type actuator shall be supplied to activate float mechanism for testing.

This control shall be similar in all respects to the Model CFF18T-H2 Flanged Float Control as manufactured by Cla-Val, Newport Beach, California, or approved equal.



CLA-VAL CFF21

Flanged float control for fuel-water separators



- **Completely automatic operation**
- **No lubrication required**
- **No adjustments required**
- **Compact and easy to install**
- **Built-in float ball and control tester**
- **Conforms to rigid military specifications**

The Cla-Val Model CFF21 Flanged Float Control is a float operated pilot control installed in the water accumulation sump of a fuel filter/separator. It is designed to automatically actuate a water drain valve (Model 100AF) and to sense a rapid accumulation of water in the sump in excess of the capacity of the drain valve. If the water level cannot be reduced by the drain valve, the float control signals the fuel discharge valve to close until the water has been drained.

The Model CFF21 Flanged Float Control features an integral tester which allows in-service testing of the pilot operation and the integrity of the float ball. Conventional testers only test the operation of the control pilot mechanism, they do not check the integrity of the float ball itself. A simple ballasting method is used in the Model CFF21 making it possible to test the operation of the control pilot and to determine if the float is sound and buoyant without the costly and time consuming process of removing the control from the separator or injecting water into the sump.

SPECIFICATIONS

MIL-F-8901, MIL-F-15618,
MIL-F-52694C and MIL-F-27629D (USAF)
-40°F to 180°F
Light petroleum products; M 1 L-G -5572, M 1 L- T -5624L and MIL-T-83133A
Aluminum - 7 lbs.
Stainless - 14 lbs.
225 PSI
Flange and Pilot Housing:
Stainless Steel ASTM A 296
Aluminum 356T6
Pilot Valve:
Stainless Steel 303
Float Ball & arm:
Stainless Steel 303

Purchase Specifications

This control shall be specifically designed to respond to changes in level of the interface surface of the water and fuel inside the water sump and shall operate the diaphragm actuated water drain valve and fuel discharge valve. The actuating fluids on the diaphragms of both the water drain valve and the fuel discharge valve shall be relieved through the pilot valve to the outlet of the water drain valve.

The float control shall consist of a mounting flange with integral pilot valve and float ball assembly. By actuation of an external lever the float ball ballast may be removed.

This action permits the float to rise in fuel verifying its buoyancy. The pilot shall be a precision-lapped, rotary disc plate type valve. Porting arrangement shall permit control of a water drain valve and a fuel discharge valve.

This control shall be the Model CFF21 Flanged Float Control as manufactured by Cla-Val Newport Beach, California.

Integral Tester Feature (Patent Pending)

In normal operating position (1) the float ball ballast is fixed to the float for automatic water level control. Removing the ballast from the float (2) allows the float ball to float in fuel (3 & 4). The sequential operation of the water drain valve and the fuel discharge valve verifies the integrity of the float ball and the proper functioning of the pilot control mechanism. This unique approach is the only positive means of totally checking the control function while the filter/separator is in service.

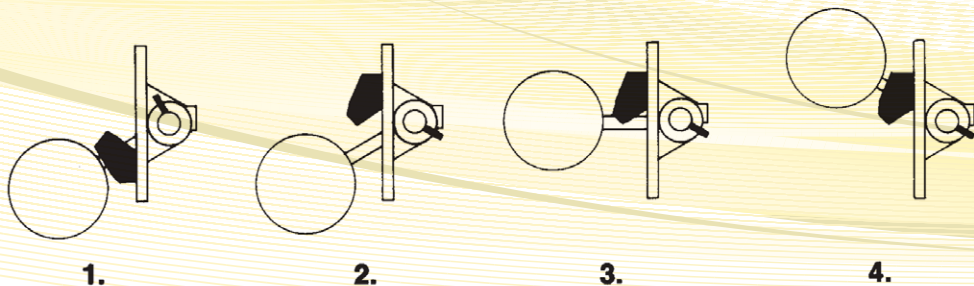



CLA-VAL CFF21

Flanged float control for fuel-water separators

Dimensions (in inches)

8 holes 1/2" diam.
spaced on 6.625 BCD

Note:
Float Ball and Arm
Dimensions will increase if
operating pressure
exceeds 225psi and/or
specific gravity of fuel is
greater than .8 (consult
factory).

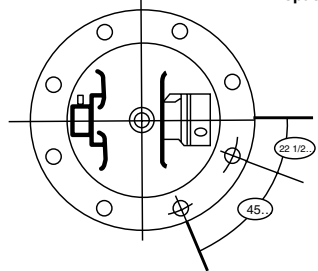
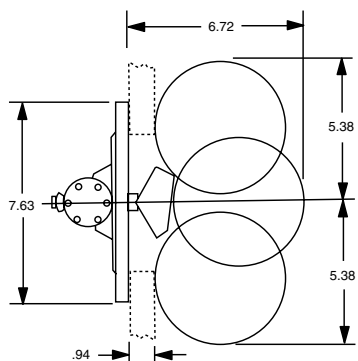

1. Flange and Pilot Materials
2. Specific Gravity of fuel
3. Operating Pressure

Typical Applications

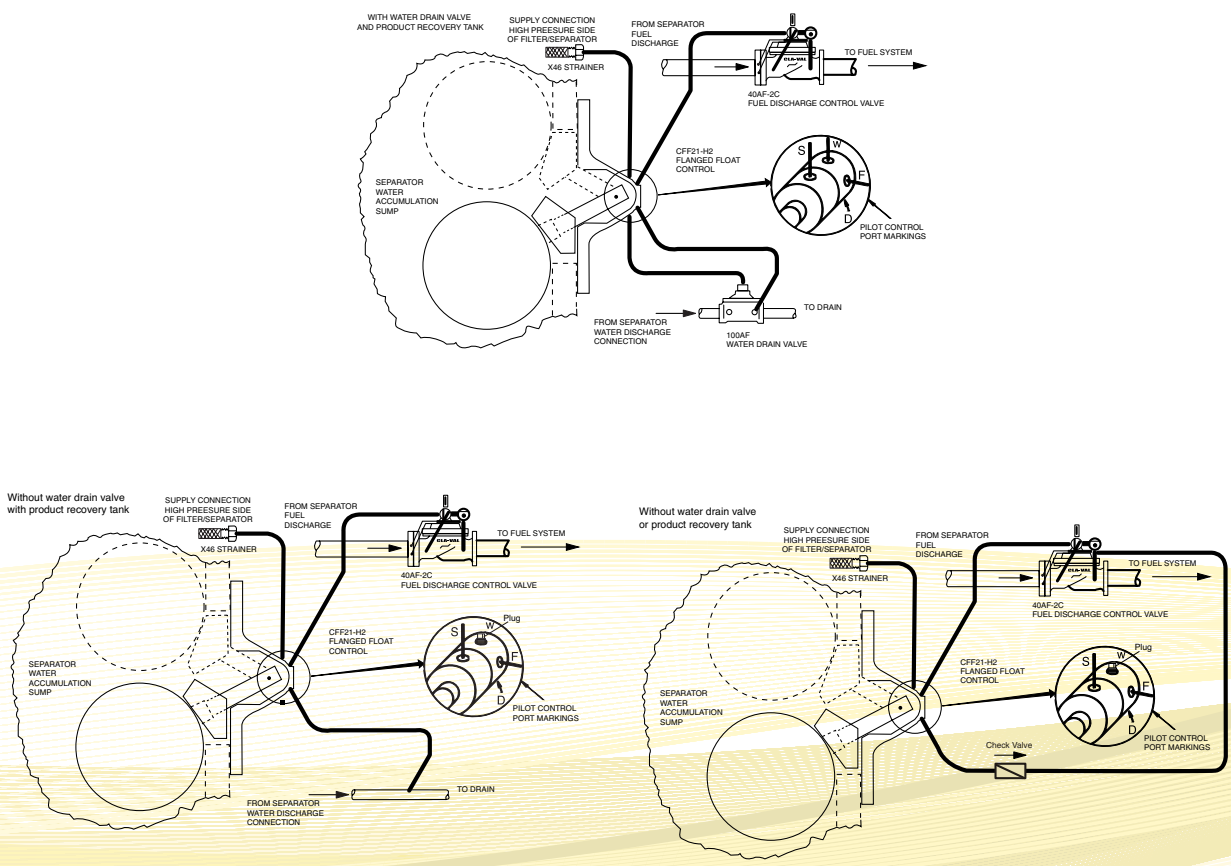

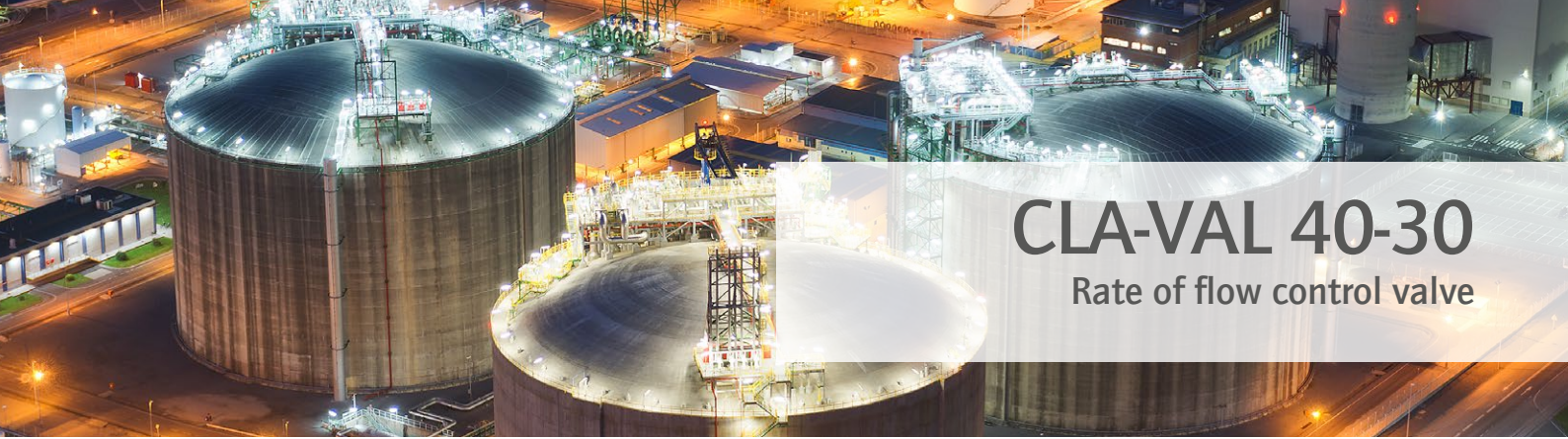

CLA-VAL 40-30

Rate of flow control valve



- **Accurately Limits Flow Rate**
- **Protects Pumps against reverse flow**
- **Surge-Free Operation**
- **Adjustable opening & closing rates**
- **Fail Safe operation**
- **Easy to Maintain**

The Cla-Val Model 40-30 Rate of Flow Non-Surge Check Valve is a hydraulically operated, pilot controlled, diaphragm actuated control valve that limits flow to a preselected maximum rate, regardless of changing line pressure. The pilot control responds to the differential pressure produced across an orifice plate installed upstream of the valve. Accurate control is assured as very small changes in the controlling differential pressure produce immediate corrective action of the main valve. The orifice bore is factory sized based on flow rate to ensure proper control valve performance. Flow rate adjustments can be made by turning an adjusting screw on the pilot control. The integrated check feature protects upstream equipment like pumps by admitting downstream pressure into the main valve cover chamber, closing the main valve upon pressure reversal.

Purchase Specifications

Pilot Control System

The 40-32 Rate of Flow Non-Surge Check Valve shall limit flow to a preselected maximum rate regardless of changing line pressure. The hydraulic control valve pilot system shall consist of a direct acting diaphragm valve designed to close when the controlling differential exceeds the adjustable spring setting. The pilot control is normally held open by the force of the compression on the spring above the diaphragm and it closes when the pressure acting on the underside of the diaphragm exceeds the spring setting. The pilot control system shall contain a fixed orifice. No variable orifices shall be permitted. A flanged orifice plate assembly shall be included and mounted to the upstream (inlet) flange. Optional pilot system features shall include (A) Flow Clean Strainer, (B) CK2 Isolation Ball Valves, (C) CV Closing Speed Control, (G) Check Feature, (Q) Quick Connect Assembly, (S) CV Opening Speed Control, (T) 55F Thermal Pressure Relief Control, (Y) X43 "Y" Strainer

Main Valve

The valve shall be hydraulically operated, single diaphragm-actuated, globe or angle pattern. It shall contain a resilient, synthetic disc with a rectangular cross-section contained on three and one-half sides by a disc retainer and forming a tight seal against a single removable seat insert. The diaphragm assembly shall be the only moving part and shall form a sealed chamber in the upper portion of the valve, separating operating pressure from line pressure. The diaphragm consists of nylon fabric bonded with synthetic rubber and shall not be used as the seating surface. The valve stem shall be fully guided at both ends by a bearing in the valve cover and an integral bearing in the valve seat. To insure proper alignment of the valve stem, the valve body and cover shall be machined with a locating lip. No "pinned" covers to the valve body shall be permitted. Packing glands and/or stuffing boxes are not permitted and there shall be no pistons operating the main valve or pilot controls. All necessary repairs and/or modifications other than replacement of the main valve body shall be possible without removing the valve from the pipeline. The valve manufacturer shall warrant the valve to be free of defects in material and workmanship for a period of three years from date of shipment, provided the valve is installed and used in accordance with all applicable instructions.

Specifications

Sizes

Globe: 1 1/2" - 16" flanged
 Angle: 2" - 16" flanged

End Details

Flanged:

Cast Aluminum, 150 ANSI B16.1
 Cast Bronze, 150 & 300 ANSI B16.24
 Ductile Iron, 150 & 300 ANSI B16.42
 Cast Steel, 150 & 300 ANSI B16.5

Temperature Range

Light Petroleum Product -40° to +140°F

Pressure Ratings

150 class 175-PSI Max
 150 class 275-PSI Max
 250 class 300-PSI Max
 300 class 400-PSI Max

Material

Body & cover:
 Cast Aluminum, 356-T6
 Cast Bronze ASTM B62
 Ductile Iron ASTM A-536
 Cast Stainless Steel 303
 Cast Steel ASTM A216-WCB

Materials (continued)

Valve trim:

Bronze ASTM B61
 Stainless Steel 303

Rubber parts:

Buna-N® Synthetic Rubber
 Viton

Other Materials

Available on Special Order

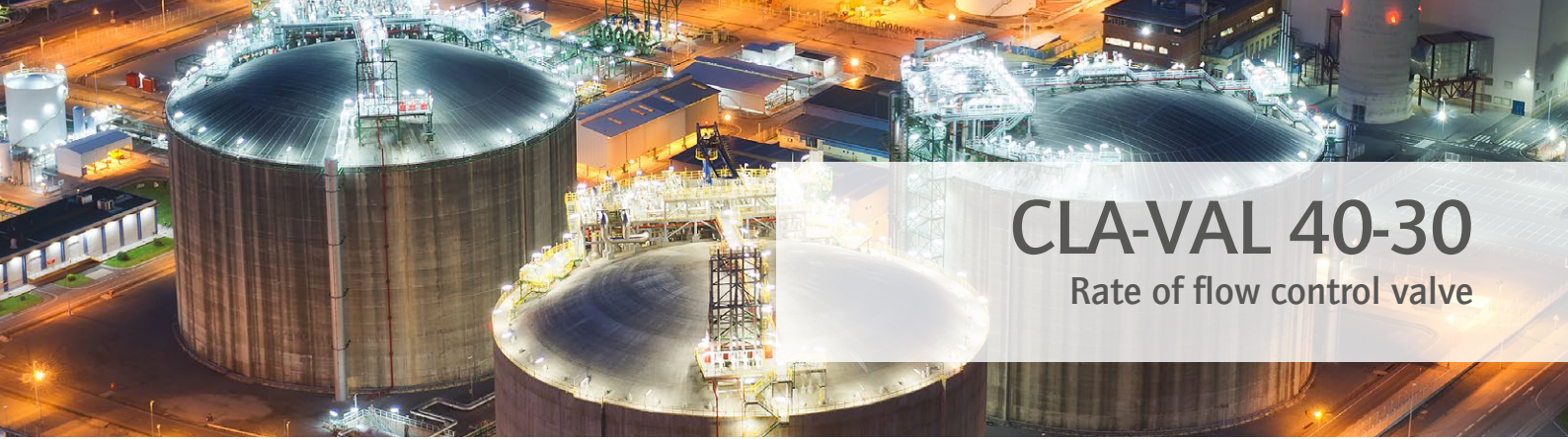

CLA-VAL 40-30

Rate of flow control valve

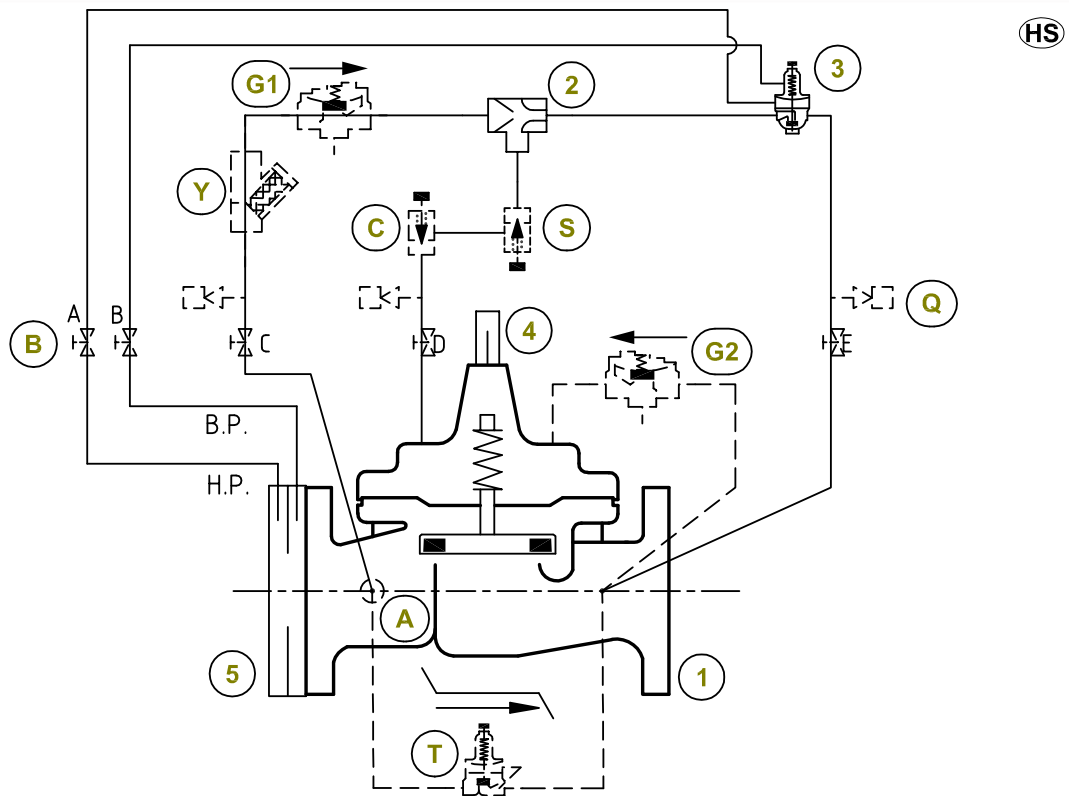

STANDARD EQUIPMENT

No	Description	Qty	Type
1	MAIN VALVE HYTROL AE/GE/NGE	1	100-34/KR *
2	EJECTOR	1	X47A
3	DIFFERENTIAL PRESSURE CONTROL	1	CDHS-2B
4	VALVE POSITION INDICATOR	1	X101
5	ORIFICE PLATE ASSEMBLY	1	X52-B

OPTIONAL FEATURES

No	Description	Qty	Type
A	FLOW CLEAN STRAINER	1	X46A
B	ISOLATION BALL VALVE	5	RB-117
C	ONE-WAY FLOW CONTROL (CLOSING SPEED)	1	CV
G	CHECK VALVE	2	81-01
Q	QUICK CONNECT ASSEMBLY	3	-
S	ONE-WAY FLOW CONTROL (OPENING SPEED)	1	CV
T	PRESSURE RELIEF VALVE	1	55F **
Y	STRAINER	1	X43

NOTES

AE/GE : DN 32 - DN 400 / NGE : DN 50 - DN 600
 (#) = According to valve size this feature type could change

NOTE :

Orifice plate assembly X52-A (5) may be fixed directly to the main valve outlet flange, however, better control is obtained, if it is mounted according to the following recommendation :
 distance X = 5x pipe diameter, distance Y = 3x pipe diameter.

* Main Valve Option : 9HS999

OPTIONAL FEATURES : _____
 NOT FURNISHED BY CLA-VAL : _____

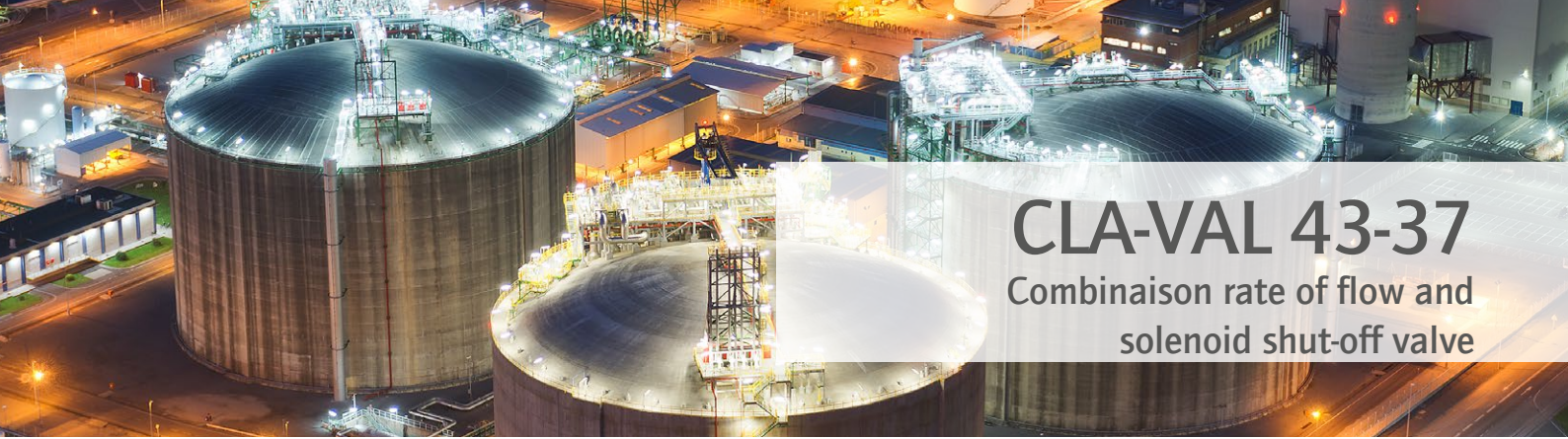

CLA-VAL 43-37

Combinaison rate of flow and solenoid shut-off valve



- **Accurately Limits Flow Rate**
- **Remote Shutoff Feature**
- **Adjustable opening & closing rates**
- **Fail Safe operation**
- **Easy to Maintain**

The Cla-Val Model 43-37 Rate of Flow and Solenoid Shutoff Valve is a hydraulically operated, pilot controlled, diaphragm actuated control valve that limits flow to a preselected maximum rate, regardless of changing line pressure. The pilot control responds to the differential pressure produced across an orifice plate installed downstream of the valve. Accurate control is assured as very small changes in the controlling differential pressure produce immediate corrective action of the main valve. The orifice bore is factory sized based on flow rate to ensure proper control valve performance. Flow rate adjustments can be made by turning an adjusting screw on the pilot control. A solenoid control is provided to intercept the operation of the differential control and close the main valve. The integrated check feature protects upstream equipment like pumps or filter separators by admitting downstream pressure into the main valve cover chamber, closing the main valve upon pressure reversal.

Purchase Specifications

Pilot Control System

The 43-37 Combination Rate of Flow Control and Solenoid Shut-off Valve shall limit flow to the preselected maximum rate regardless of changing line pressure when activated by a solenoid control. The pilot system shall consist of a direct acting diaphragm valve designed to close when the controlling differential exceeds the adjustable spring setting. The pilot control is normally held open by the force of the compression on the spring above the diaphragm and it closes when the pressure acting on the underside of the diaphragm exceeds the spring setting. The pilot control system shall contain a fixed orifice. No variable orifices shall be permitted. A flanged orifice plate assembly shall be included and mounted to the downstream (outlet) flange. Optional pilot system features shall include (A) Flow Clean Strainer, (B) CK2 Isolation Ball Valves, (C) CV Closing Speed Control, (G) Check Feature, (Q) Quick Connect Assembly, (S) CV Opening Speed Control, (T) 55F Thermal Pressure Relief Control, (Y) X43 "Y" Strainer.

Main Valve

The valve shall be hydraulically operated, single diaphragm-actuated, globe or angle pattern. It shall contain a resilient, synthetic disc with a rectangular cross-section contained on three and one-half sides by a disc retainer and forming a tight seal against a single removable seat insert. The diaphragm assembly shall be the only moving part and shall form a sealed chamber in the upper portion of the valve, separating operating pressure from line pressure. The diaphragm consists of nylon fabric bonded with synthetic rubber and shall not be used as the seating surface. The valve stem shall be fully guided at both ends by a bearing in the valve cover and an integral bearing in the valve seat. To insure proper alignment of the valve stem, the valve body and cover shall be machined with a locating lip. No "pinned" covers to the valve body shall be permitted. Packing glands and/or stuffing boxes are not permitted and there shall be no pistons operating the main valve or pilot controls. All necessary repairs and/or modifications other than replacement of the main valve body shall be possible without removing the valve from the pipeline. The valve manufacturer shall warrant the valve to be free of defects in material and workmanship for a period of three years from date of shipment, provided the valve is installed and used in accordance with all applicable instructions.

Specifications

Sizes

Globe: 1 1/2" - 16" flanged
Angle: 2" - 16" flanged

End Details

Flanged:

Cast Aluminum, 150 ANSI B16.1
Cast Bronze, 150 & 300 ANSI B16.24
Ductile Iron, 150 & 300 ANSI B16.42
Cast Steel, 150 & 300 ANSI B16.5

Temperature Range

Light Petroleum Product -40° to +140°F

Pressure Ratings

150 class 175-PSI Max.
150 class 275-PSI Max.
250 class 300-PSI Max.
300 class 400-PSI Max.

Material

Body & cover:

Cast Aluminum 356-T6
Cast Bronze ASTM B62
Ductile Iron ASTM A-536
Cast Stainless Steel 303
Cast Steel ASTM A216-WCB

Valve trim:

Bronze ASTM B61
Stainless Steel 303

Rubber parts:

Buna-N® Synthetic Rubber
Viton

Other Materials

Available on Special Order

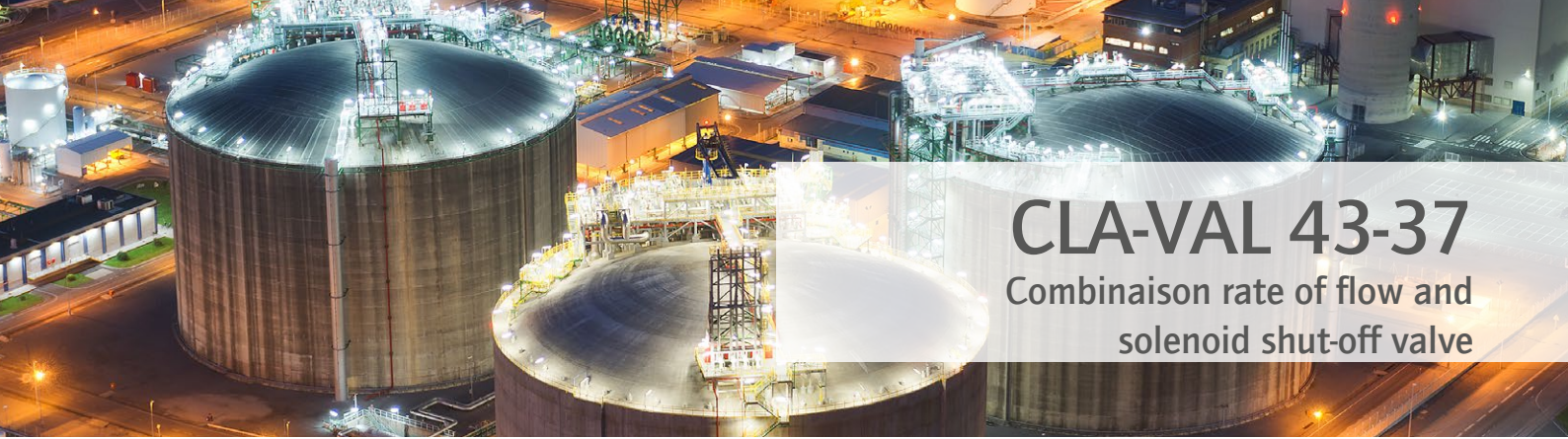

CLA-VAL 43-37

Combinaison rate of flow and solenoid shut-off valve

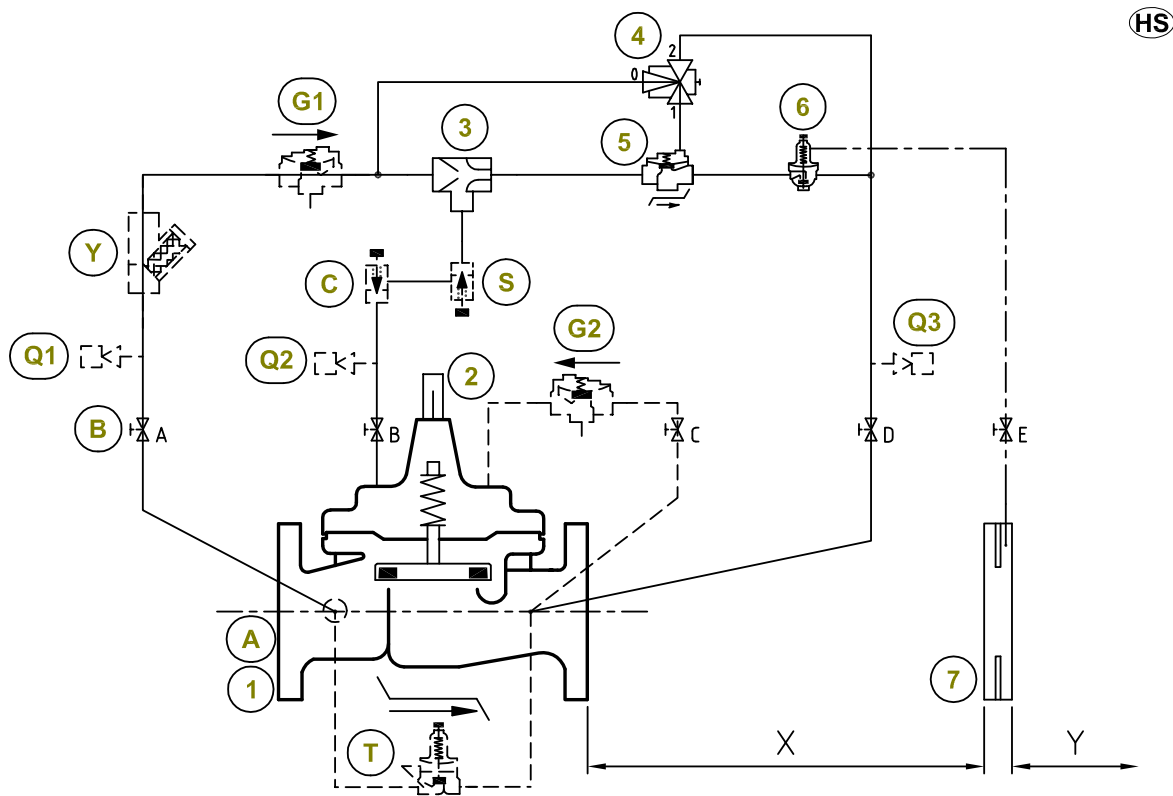

STANDARD EQUIPMENT

No	Description	Qty	Type
1	MAIN VALVE HYTROL AE/GE/NGE	1	100-34 */KR
2	VALVE POSITION INDICATOR	1	X101
3	EJECTOR	1	X47A
4	3-WAY SOLENOID VALVE (NO)	1	311-D
5	AUXILIARY VALVE HYTROL	1	100-KHR
6	DIFFERENTIAL PRESSURE CONTROL	1	CDHS-18
7	ORIFICE PLATE ASSEMBLY	1	X52-A

OPTIONAL FEATURES

No	Description	Qty	Type
A	FLOW CLEAN STRAINER	1	X46A
B		5	RB-117
C	ONE-WAY FLOW CONTROL (CLOSING SPEED)	1	CV
G	CHECK VALVE	2	81-01
Q	QUICK CONNECT ASSEMBLY	3	-
S	ONE-WAY FLOW CONTROL (OPENING SPEED)	1	CV
T	PRESSURE RELIEF VALVE	1	55F **
Y	STRAINER	1	X43

NOTES

AE/GE : DN 32 - DN 400 / NGE : DN 50 - DN 600
 (#) = According to valve size this feature type could change

OPTIONAL FEATURES : — — — — —
 NOT FURNISHED BY CLA-VAL : - - - - -

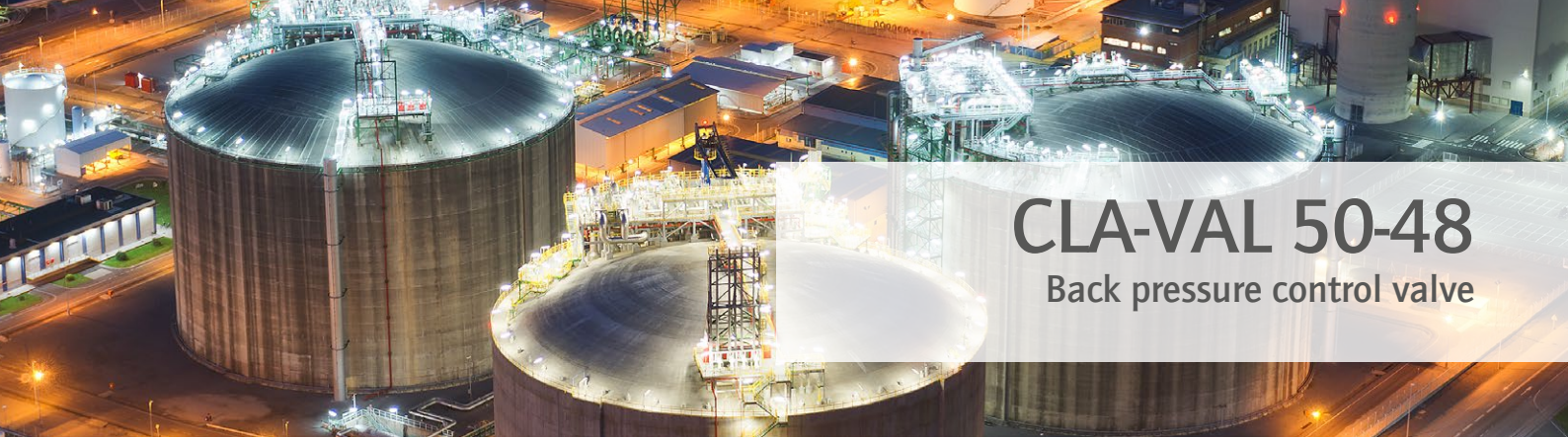

CLA-VAL 50-48

Back pressure control valve



- **Rapid Opening to relieve excess pressure**
- **Modulates to maintain constant back pressure**
- **Slow, adjustable closing speed prevents system surges**
- **Optional check feature to prevent reverse flow**

The Cla-Val Model 50-48 Pressure Relief & Back Pressure Valve is a hydraulically operated, pilot-controlled, modulating valve designed to maintain constant upstream pressure within close limits. This valve can be used for pressure relief, pressure sustaining, back pressure, or unloading functions in a by-pass system. In relief applications, the valve opens fast to prevent upstream pressure from exceeding the maximum pressure setting while closing gradually to prevent a surge in the system. In back pressure control applications, the valve modulates to maintain constant upstream pressure, regardless of changes in demand, preventing the upstream pressure from falling below the minimum pressure setting. Operation is completely automatic and pressure setting is easily adjusted. If a check feature is added and a pressure reversal occurs, the downstream pressure is admitted into the main valve cover chamber, closing the valve to prevent return flow.

Purchase Specifications

The valve shall be hydraulically operated, diaphragm-actuated, globe or angle pattern valve. It shall contain a resilient, synthetic rubber disc, having a rectangular cross section, contained on three and on-half sides by a disc retainer and disc guide, forming a tight seal against a single renewable seat. The valve stem shall be guided at both ends by a bearing in the valve cover and an integral bearing in the valve seat. The diaphragm assembly shall be the only moving part and shall form a sealed chamber in the upper portion of the valve, separating operating pressure from line pressure. The diaphragm consist of nylon fabric bonded with synthetic rubber and shall not be used as a seating surface. Packing glands and/or stuffing boxes are not permitted and there shall be no pistons operating the valve. All necessary repairs shall be possible without removing the valve from the line. If the diaphragm becomes damaged the valve shall open. This valve shall be a Model 100-34 (globe pattern or angle pattern) Hytrol Valve as manufactured by Cla-Val, Newport Beach, California.

Specify When Ordering

1. Size
2. Model 50-48 Globe or Angle
3. Pressure Class
4. Temperature and fluid to be handled
5. Static and flowing line pressure
6. Operating fluid and pressure (if other than line pressure)
7. Body and trim materials
8. End details

Specifications

Sizes

Globe: 1 1/2" - 16" flanged
Angle: 2" - 16" flanged

End Details

Flanged:
Cast Aluminum, 150 ANSI B16.1
Cast Bronze, 150 & 300 ANSI B16.24
Ductile Iron, 150 & 300 ANSI B16.42
Cast Steel, 150 & 300 ANSI B16.5

Temperature Range

Light Petroleum Product -40° to +140°F

Pressure Ratings

150 class 175-PSI Max.
150 class 275-PSI Max.
250 class 300-PSI Max.
300 class 400-PSI Max.

Material

Body & cover:
Cast Aluminum 356-T6
Cast Bronze ASTM B62
Ductile Iron ASTM A-536
Cast Stainless Steel 303
Cast Steel ASTM A216-WCB

Valve trim:

Bronze ASTM B61
Stainless Steel 303

Rubber parts:

Buna-N® Synthetic Rubber
Viton

Other Materials

Available on Special Order

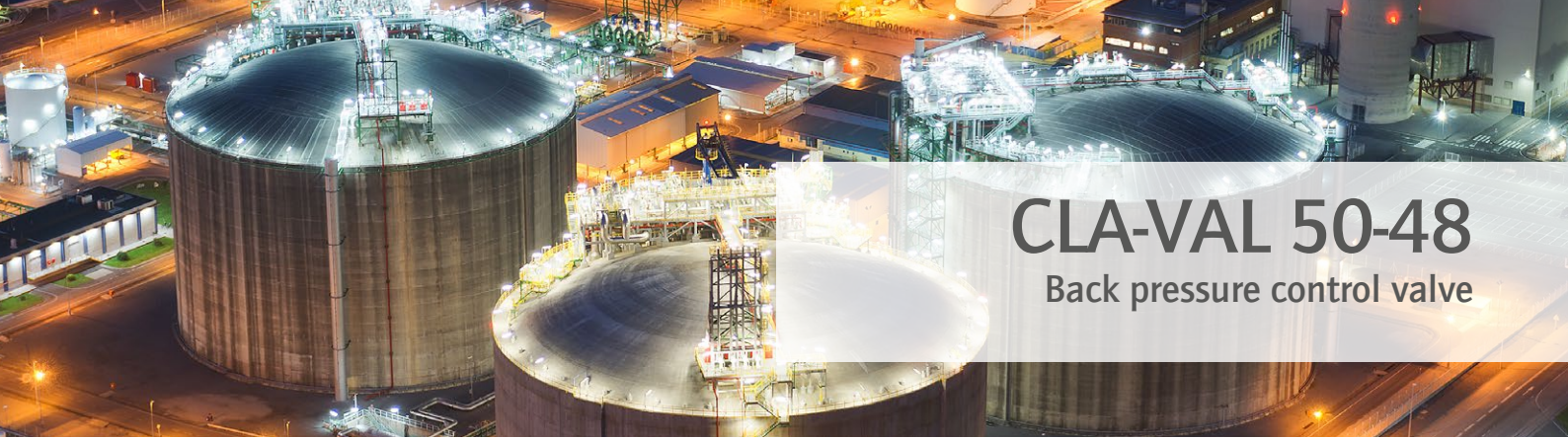

CLA-VAL 50-48

Back pressure control valve

HS

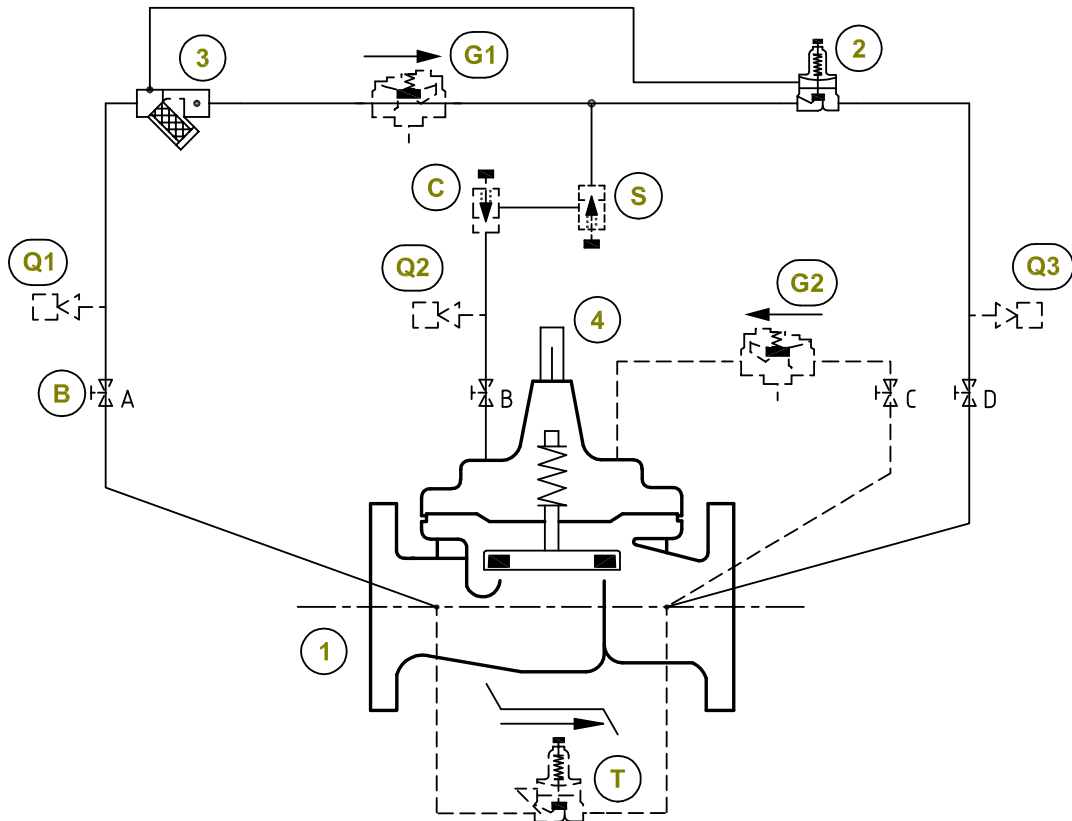

STANDARD EQUIPMENT

No	Description	Qty	Type
1	MAIN VALVE HYTROL AE/GE/NGE	1	100-34 *
2	PRESSURE RELIEF CONTROL	1	CRL
3	STRAINER WITH INCORPORATED ORIFICE	1	X44-A
4	VALVE POSITION INDICATOR	1	X101

OPTIONAL FEATURES

No	Description	Qty	Type
B	ISOLATION BALL VALVE	4	RB-117
C	ONE-WAY FLOW CONTROL (CLOSING SPEED)	1	CV
G	CHECK VALVE	2	81-01
Q	QUICK CONNECT ASSEMBLY	3	-
S	ONE-WAY FLOW CONTROL (OPENING SPEED)	1	CV
T	PRESSURE RELIEF VALVE	1	55F

NOTES

AE/GE : DN 32 - DN 400 / NGE : DN 50 - DN 600
 * Main Valve option : 9HS999

OPTIONAL FEATURES : _____
 NOT FURNISHED BY CLA-VAL : _____

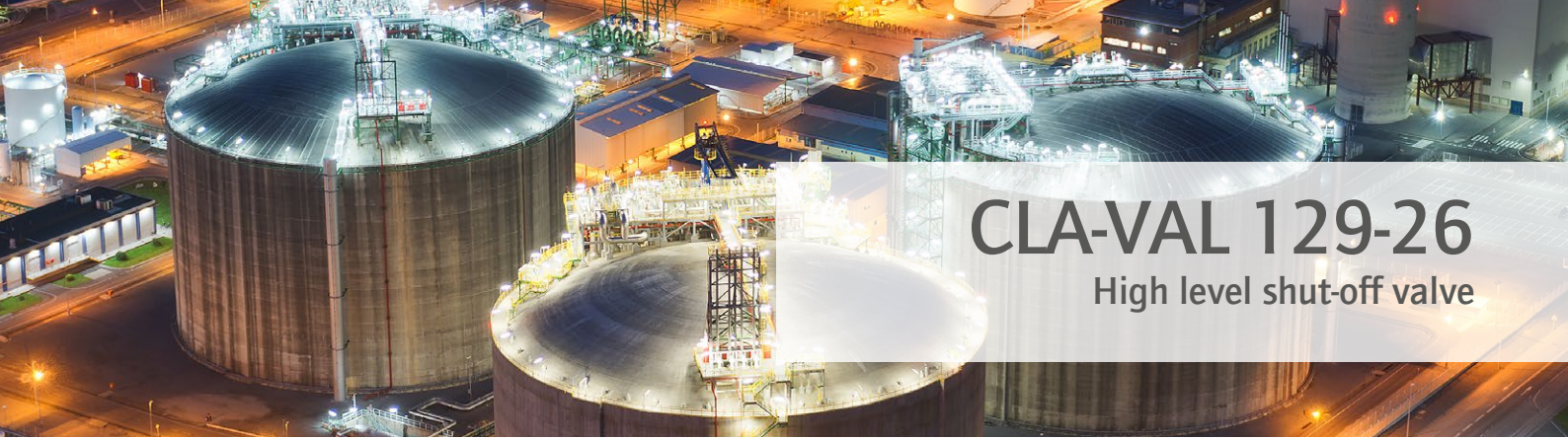

CLA-VAL 129-26

High level shut-off valve



- Installed in the fill line to either underground or above ground fuel storage tanks
- Pilot control and hydraulically operated by line pressure, closing fully when tank is full
- Provides accurate, repeatable high level shut-off
- Can be serviced without removal of valve from line
- Fail-safe operation
- Position indicator is standard
- Available in aluminum, cast steel, stainless steel or ductile iron

The Cla-Val Model 129-26 Hytrol Valve is used as the basic unit in almost all Cla-Val automatic control valves for petroleum applications. The 129-26 is a hydraulically-operated, diaphragm actuated, globe or angle pattern valve. It is available in various materials and full range of sizes. It consists of three major components: body, diaphragm assembly and cover. The diaphragm assembly is the only moving part. The rugged simplicity of design and packless construction assure a long life dependable, trouble-free operation. Should the diaphragm become damaged the valve will close tight, providing "fail safe" operation. The 129-26 Hytrol Valve is used in many types of piping system requiring control, flow regulation, rate of flow control, or check valve operation.

Purchase Specifications

The valve shall be hydraulically-operated, diaphragm-actuated, globe or angle pattern valve. It shall contain a resilient, synthetic rubber disc, having a rectangular cross section, contained on three and on-half sides by a disc retainer and disc guide, forming a tight seal against a single renewable seat. The valve stem shall be guided at both ends by a bearing in the valve cover and an integral bearing in the valve seat. The diaphragm assembly shall be the only moving part and shall form a sealed chamber in the upper portion of the valve, separating operating pressure from line pressure. The diaphragm consist of nylon fabric bonded with synthetic rubber and shall not be used as a seating surface. Packing glands and/or stuffing boxes are not permitted and there shall be no pistons operating the valve. All necessary repairs shall be possible without removing the valve from the line. If the diaphragm becomes damaged the valve shall close tight. This valve shall be a Model 100-34 (globe pattern or angle pattern) Hytrol Valve as manufactured by Cla-Val. Newport Beach, California.

Specify When Ordering

1. Size
2. Model 129-26 Globe or Angle
3. Pressure Class
4. Temperature and fluid to be handled
5. Static and flowing line pressure
6. Operating fluid and pressure (if other than line pressure)
7. Body and trim materials
8. End details

Specifications

Sizes

Globe: 1 1/2" - 16" flanged
 Angle: 2" - 16" flanged

End Details

Flanged:

Cast Aluminum, 150 ANSI B16.1
 Cast Bronze, 150 & 300 ANSI B16.24
 Ductile Iron, 150 & 300 ANSI B16.42
 Cast Steel, 150 & 300 ANSI B16.5

Temperature Range

Light Petroleum Product -40° to+140°F

Pressure Ratings

150 class 175-PSI Max.
 150 class 275-PSI Max.
 250 class 300-PSI Max.
 300 class 400-PSI Max.

Material

Body & cover:

Cast Aluminum 356-T6
 Cast Bronze ASTM B62
 Ductile Iron ASTM A-536
 Cast Stainless Steel 303
 Cast Steel ASTM A216-WCB

Valve trim:

Bronze ASTM B61
 Stainless Steel 303

Rubber parts:

Buna-N® Synthetic Rubber
 Viton

Other Materials

Available on Special Order



CLA-VAL 129-26

High level shut-off valve

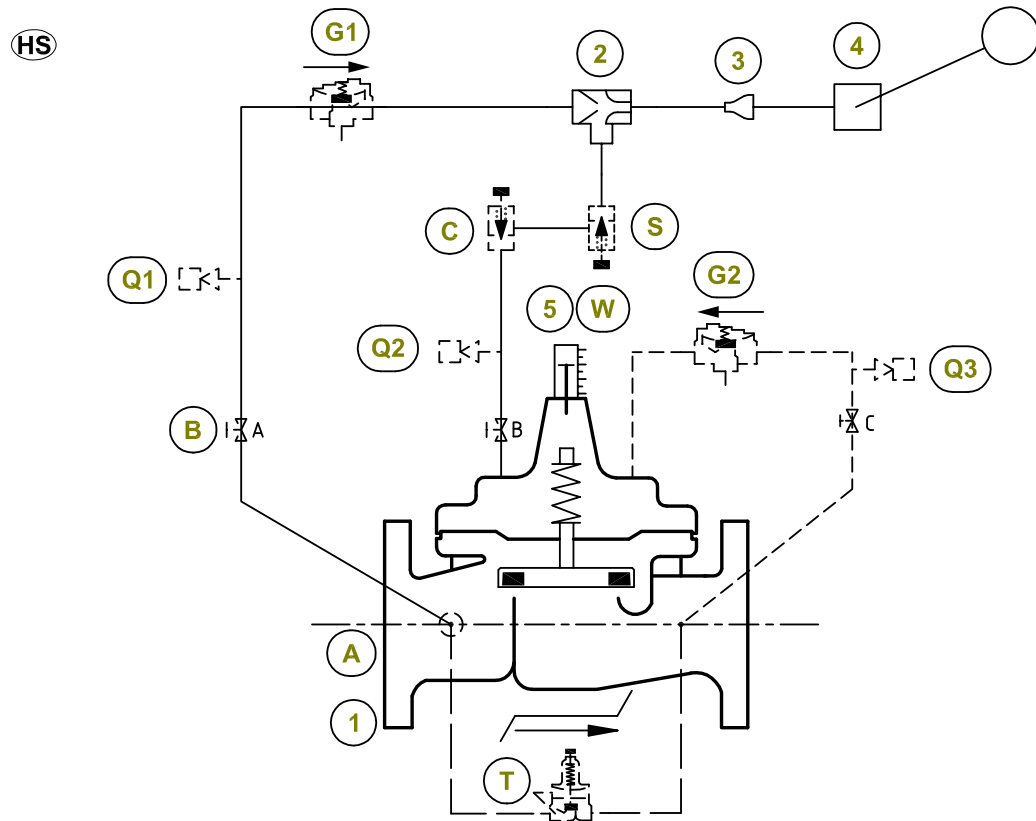

STANDARD EQUIPMENT

No	Description	Qty	Type
1	MAIN VALVE HYTROL AE/GE/NGE	1	100-34
2	EJECTOR	1	X47A
3	BELL REDUCER	1	
4	2-WAY MODULATING FLOAT LEVEL CONTROL	1	CFM2
5	VALVE POSITION INDICATOR	1	X101

OPTIONAL FEATURES

No	Description	Qty	Type
A	FLOW CLEAN STRAINER	1	X46A
B	ISOLATION BALL VALVE	2	RB-117
C	ONE-WAY FLOW CONTROL (CLOSING SPEED)	1	CV
G	CHECK VALVE	2	81-01
Q	QUICK CONNECT ASSEMBLY	3	-
T	PRESSURE RELIEF VALVE	1	55F
S	ONE-WAY FLOW CONTROL (OPENING SPEED)	1	CV
W	SWITCH ASSEMBLY	1	X105-L

NOTES

AE/GE : DN 32 - DN 400 / NGE : DN 50 - DN 600
 (#) = According to valve size this feature type could change

OPTIONAL FEATURES : _____
 NOT FURNISHED BY CLA-VAL : _____



CLA-VAL 131-CP

Electronic interface control valve



- **Ideal for loading or process control applications**
- **Simple Proven Design**
- **Multi-Function Capability**
- **Hydraulic Override Features Available**
- **Easy to Maintain**

The Model 131-CP Electronic Interface Control Valve is designed for applications where remote electronic control is required. It is a hydraulically operated, pilot controlled, diaphragm actuated control valve. These valves are regularly used to provide process control, flow control, and / or pressure control in two-stage loading, bypass, pressure sustaining, or pressure reducing applications. The valve is equipped with two direct-acting two-way solenoids. Upon actuation by a Cla-Val Electronic Controller or other PLC, the solenoid pilot controls either add or relieve line pressure to / from the cover chamber of the valve, causing it to close or open. The 131-CP valve is a fail-safe valve equipped with a manual bypass feature and can also incorporate hydraulic override features.

Purchase Specifications

Pilot Control System

The 131-CP hydraulic control valve pilot system shall consist of dual solenoids which alternately apply or relieve pressure to the diaphragm chamber to position the main valve. The closing solenoid (inlet) shall be normally open (energized to close) while the opening solenoid (outlet) shall be normally closed (energized to open). A manual system to bypass the solenoids shall also be provided. Optional pilot system features shall include (A) Flow Clean Strainer, (B) CK2 Isolation Ball Valves, (C) CV Closing Speed Control, (G) Check Feature, (Q) Quick Connect Assembly, (S) CV Opening Speed Control, (T) 55F Thermal Pressure Relief Control, (Y) X43 "Y" Strainer.

Main Valve

The valve shall be hydraulically operated, single diaphragm-actuated, globe or angle pattern. It shall contain a resilient, synthetic disc with a rectangular cross-section contained on three and one-half sides by a disc retainer and forming a tight seal against a single removable seat insert. The diaphragm assembly shall be the only moving part and shall form a sealed chamber in the upper portion of the valve, separating operating pressure from line pressure. The diaphragm consists of nylon fabric bonded with synthetic rubber and shall not be used as the seating surface. The valve stem shall be fully guided at both ends by a bearing in the valve cover and an integral bearing in the valve seat. To insure proper alignment of the valve stem, the valve body and cover shall be machined with a locating lip. No "pinned" covers to the valve body shall be permitted. Packing glands and/or stuffing boxes are not permitted and there shall be no pistons operating the main valve or pilot controls. All necessary repairs and/or modifications other than replacement of the main valve body shall be possible without removing the valve from the pipeline. The valve manufacturer shall warrant the valve to be free of defects in material and workmanship for a period of three years from date of shipment, provided the valve is installed and used in accordance with all applicable instructions. Electrical components shall have a one-year warranty.

Specifications

Sizes

Globe: 1 1/2" - 16" flanged
Angle: 2" - 16" flanged

End Details

Flanged:

Cast Aluminum, 150 ANSI B16.1
Cast Bronze, 150 & 300 ANSI B16.24
Ductile Iron, 150 & 300 ANSI B16.42
Cast Steel, 150 & 300 ANSI B16.5

Temperature Range

Light Petroleum Product -40° to +140°F

Pressure Ratings

150 class 175-PSI Max.
150 class 275-PSI Max.
250 class 300-PSI Max.
300 class 400-PSI Max.

Material

Body & cover:

Cast Aluminum 356-T6
Cast Bronze ASTM B62
Ductile Iron ASTM A-536
Cast Stainless Steel 303
Cast Steel ASTM A216-WCB

Valve trim:

Bronze ASTM B61
Stainless Steel 303

Rubber parts:

Buna-N® Synthetic Rubber
Viton

Other Materials

Available on Special Order



CLA-VAL 131-CP

Electronic interface control valve

HS

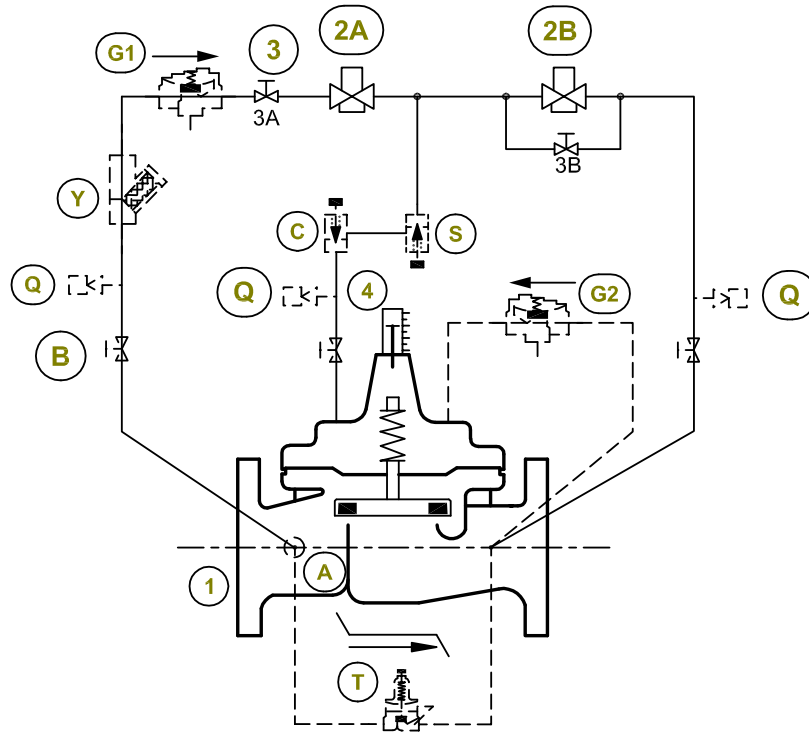

STANDARD EQUIPMENT

No	Description	Qty	Type
1	MAIN VALVE HYTROL AE/GE/NGE	1	100-34/KR
2A	3-WAY SOLENOID VALVE (NO)	1	122V
2B	3-WAY SOLENOID VALVE (NC)	1	121V
3	ISOLATION BALL VALVE (3B LOCKABLE)	2	RB-117
4	VALVE POSITION INDICATOR	1	X101

OPTIONAL FEATURES

No	Description	Qty	Type
A	FLOW CLEAN STRAINER	1	X46A
B	ISOLATION BALL VALVE	3	RB-117
C	ONE-WAY FLOW CONTROL (CLOSING SPEED)	1	CV
G	CHECK VALVE	2	81-01
Q	QUICK CONNECT ASSEMBLY	3	-
S	ONE-WAY FLOW CONTROL (OPENING SPEED)	1	CV
T	PRESSURE RELIEF VALVE	1	55F **
Y	STRAINER	1	X43

NOTES

AE/GE : DN 32 - DN 400 / NGE : DN 50 - DN 600
 *MAIN VALVE OPTIONS = 9HS999

OPTIONAL FEATURES : — — — — —
 NOT FURNISHED BY CLA-VAL : - - - - -



CLA-VAL 72-401

Two stage set stop valve

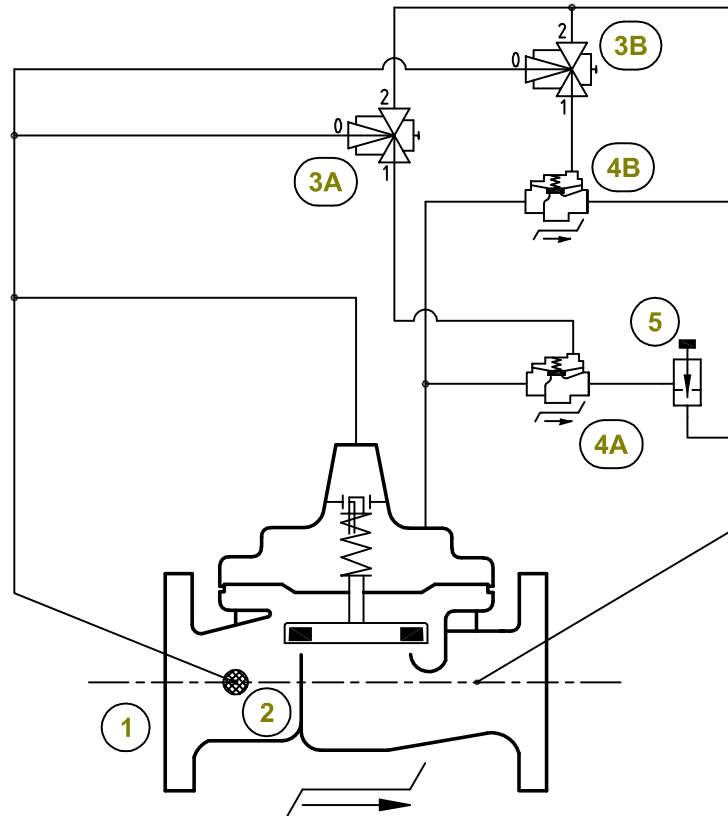

STANDARD EQUIPMENT

No	Description	Qty	Type
1	MAIN VALVE HYTROL AE/GE/NGE	1	100-34/X743KR*
2	FLOW CLEAN STRAINER	1	X46A
3	3-WAY SOLENOID VALVE (NO)	2	311-D
4	AUXILIARY VALVE HYTROL	2	100-KHR
5	NEEDLE VALVE	1	6120

OPTIONAL FEATURES

No	Description	Qty	Type

NOTES

AE/GE : DN 50 - DN 100 / NGE : DN 65 - DN 150

(1) 100-34/X143KR = 9HS999

(#) = According to valve size this feature type could change

OPTIONAL FEATURES : _____
 NOT FURNISHED BY CLA-VAL : _____



Terms and Conditions of Sale and Warranty



Terms and Conditions of Sale and Warranty

I GENERAL

Until otherwise agreed, in writing, the following conditions are valid. The Buyer, as referred into the terms of sale, is a CLA-VAL Europe customer.

II PRICE

1. Our prices are net, ex works and subject to packing and carriage charges. The prices are exclusive of any applicable VAT.
2. VAT is charged extra at the rate applicable at the time of invoicing.
3. Freight and packaging (wooden crates, pallets etc) will be charged at cost for each shipment.
4. Orders with a net value of less than CHF 150 (EUR 100) will be subject to a CHF 150 (EUR 100) handling fee.
5. All order modifications made 48 hours after order acknowledgement will be subject to a CHF 150 (EUR 100) handling fee. CLA-VAL Europe reserves to charge additional costs depending on production processing status of the order as well as modification cost consequences on open order.
6. No handling fee will be applied to orders placed through the CLA-VAL Europe internet ordering system (www.cla-val.ch).
7. We reserve the right to make partial deliveries, which can be invoiced separately.
8. We reserve the right, if freight was quoted, to charge fuel increase at time of shipment.
9. If not quoted, tests, certificates, special documents, legalisation, installation and commissioning are not included in our prices and will be charged according the CLA-VAL Europe IT421 price list.
10. Quotation validity 3 months from the date of issue.

III PAYMENT

1. For any national order (territories: Switzerland, France, UK and Ireland) we request 30 days net payment due from the shipment date (or dispatch date) from one of our Euro locations.
2. For any national signed framework agreements (territories: Switzerland, France, UK and Ireland) where business volume is granted, payment terms could be adapted but must be approved by the Managing Director in charge of the said CLA-VAL Euro location.
3. For any international order CLA-VAL Europe can request, on a case by case basis, a L/C (Letter of Credit) opened with a CLA-VAL Europe approved bank and referring to CLA-VAL Europe L/C standards.
4. For day to day international business below EUR 10'000 with established European Distributors we request 30 days net payment due from the shipment date (or dispatch date) from one of our Euro locations.
5. For day to day international business below EUR 10'000 with non European Distributors we request maximum 90 days net payment due from the shipment date (or dispatch date) from one of our Euro locations.
6. For all new international customers advance payment or Letter of Credit is requested.
7. Advanced payment is considered to be 100%.
8. CLA-VAL Europe does not accept any liquidated damages, penalties or retention.

IV TITLE AND RISK

The Buyer becomes owner of the goods as per Incoterms.
The Buyer is responsible for cover against all risks of loss, damage or destruction of goods until full payment has been made to CLA-VAL Europe.
The Buyer shall store and label all goods belonging to CLA-VAL Europe for which payment has not been made so that the goods shall be identified as such.

V DAMAGE OR LOSS IN TRANSIT¹

CLA-VAL Europe assumes no liability for damage or loss of shipment. All shipments should be unpacked and examined immediately upon receipt. Any external evidence or loss or damage must be noted on the freight bill or carrier's receipt and signed by the carrier's agent at the time of delivery. Failure to do so will result in the carrier's refusal to honour the claim. Buyer should then notify CLA-VAL Europe with a copy of the freight bill or damage report so that CLA-VAL Europe then can file a claim for loss or damage in transit with the carrier. If damage does not become apparent until shipment is unpacked, customer must make a request for inspection by the carrier's agent and file with the carrier within 15 days after receipt of product and notify CLA-VAL Europe. CLA-VAL Europe is not liable for consequential damages resulting from the installation of damaged product.

VI DELIVERY

Any dates for delivery, although quoted in good faith, are estimates only and CLA-VAL Europe shall not be liable for any delay in delivery of the goods however caused.

CLA-VAL Europe undertakes to match its delivery estimate but does not accept cancellation of order or liability for any direct or indirect losses which may arise, for any reason whatsoever, from our failure to match to such estimate.

VII ORDER CANCELLATION

Orders are not subject to cancellation or change in specifications, shipping schedules or other conditions originally agreed upon without CLA-VAL's written consent and then only upon agreement to compensate the CLA-VAL Europe for loss caused by such cancellation or changes.

In the event that the buyer cancels all or parts of an order, once confirmed, the buyer is subject to a 50% cancellation fee of the amount as stipulated in the Order Acknowledgement.

The buyer is obligated to accept and pay for any product build and ordered as non-standard product or solution product.

VIII RETURN OF GOODS

1. Buyer must obtain written approval from CLA-VAL Europe prior returning any material.
2. CLA-VAL Europe reserves the right to refuse the return of any product.
3. Only goods in original packaging can be accepted. Goods returned must be in condition for resale as new equipment to qualify for credit.
4. Products more than **six (6) months** old cannot be returned for credit.
5. Specially produced, non-standard models cannot be returned for credit.
6. Rubber goods such as diaphragms, discs, o-rings, etc..., cannot be returned for credit.
7. Goods authorized for return are subject to a **50% (min. 100 Euro / 150 CHF) restocking charge and a service charge** for inspection, replacement of rubber parts, retesting, repainting and repackaging. Authorized returned goods must be packaged and shipped prepaid to CLA-VAL Europe - Switzerland.



Terms and Conditions of Sale and Warranty

I WARRANTY

1. Automatic valves and controls manufactured by CLA-VAL Europe are warranted for three (3) years from date of shipment against manufacturing defects in material and workmanship which develop in the service for which they are designed, provided the products are installed and used in accordance with all applicable instructions and limitations issued by CLA-VAL Europe. Normal wear is not covered by this warranty.
2. We will repair or replace defective material, free of charge which is returned to our factory, transportation charges prepaid, provided that after inspection the material is found to have been defective at time of shipment.
3. This warranty is expressly conditioned on the Buyer's giving CLA-VAL Europe immediate written notice upon discovery of the defect.
4. Electronic components manufactured by CLA-VAL Europe are warranted for one (1) year from the date of shipment.
5. Rechargeable lead batteries and super capacitors are warranted for six (6) months from the date of shipment.
6. CLA-VAL Europe warranty does not cover dry batteries and rechargeable Li-Ion or Ni-Mh batteries.
7. Components used by CLA-VAL Europe, but manufactured by others, are warranted only to the extent of that manufacturer's guarantee.
8. This warranty shall not apply if the product has been altered, repaired, adjusted or modified by non CLA-VAL Europe employees or specially CLA-VAL Europe trained technicians, and CLA-VAL Europe shall make no allowance or credit for such repairs or alterations unless authorized in writing by CLA-VAL Europe.
9. Repaired, replaced or exchanged product will be warranted for the repair warranty period which comes into effect as of the date the repaired, exchanged or replaced product is shipped by CLA-VAL Europe, or the remainder of the original warranty, whichever is longer.
10. Products found to be defective for which warranty is applicable will be replaced or repaired at CLA-VAL's discretion. CLA-VAL Europe is not responsible for charges resulting from the removal and/or replacement of product.
11. Before removing a product from the installation we suggest contact an AUTHORIZED CLA-VAL Europe technical support technician.
12. The CLA-VAL Europe specialist will work with the field technician to troubleshoot the problem. (Many problems are site-related and can be solved over the phone.)
13. New products ordered in an attempt to circumvent the warranty process may not be reimbursed if, upon receipt of a returned product, it is determined that the product defect is actually field related, or product has been returned for cosmetic reasons only.
14. Due to vibration in shipping CLA-VAL Europe products, we strongly recommend checking all tubing, fittings and cover bolts prior to system start up.

II DISCLAIMER OF WARRANTIES & LIMITATION OF LIABILITY

The foregoing warranty is exclusive and in lieu of all other warranties and representations whether expressed, implied, oral or written, including but not limited to, any implied warranties or merchantability or fitness for a particular purpose. All such other warranties and representations are hereby cancelled. CLA-VAL Europe shall not be liable for any incidental or consequential loss, damage or expense arising directly or indirectly from the use of the product.

CLA-VAL Europe shall not be liable for any damages or charges for labour or expense in making repairs or adjustments to the product. CLA-VAL Europe shall not be liable for any damages or charges sustained in the adaptation or use of its engineering data and services.

No representative of CLA-VAL Europe may change any of the foregoing or assume any additional liability or responsibility in connection with the product. The liability of CLA-VAL Europe is limited to material replacements, Ex-Works CLA-VAL Europe.

The liability of the CLA-VAL Europe is defined conclusively in section X.

Any other buyer claims towards CLA-VAL Europe, irrespective upon which legal basis these are made, especially those concerning price reduction or cancellation, are excluded and expressly dismissed.

III FORCE MAJEURE

Neither CLA-VAL Europe nor the Buyer accept liability for damage of any kind if obstacles occur which they are unable to prevent despite all due care, irrespective of whether these occur at the site of CLA-VAL Europe, the Buyer or a third party. Such obstacles as for example, epidemics, mobilization, war, uprisings, serious operational problems, accidents, labour disputes, delayed faulty delivery of the required raw materials, semi-finished finished goods, off-spec rejection of important work piece institutional measures or injunctions, natural hazards or other circumstances which are, to a large extent, not within the scope of control of the CLA-VAL Europe or the Buyer. However, payment may not be retained or delayed for product(s) delivered to Buyer with reference to such circumstances. In such case both parties shall undertake all effective measures, which can be expected of them to prevent damage, or if damage occurs to minimize the scope of this damage as far as possible.

IV NON-STOCK AND NON-CATALOGUE ITEMS

Products not listed in the current price list or catalogues are considered to be special order items and subject to minimum order quantities, special handling charges, and/or other condition stipulated to us by suppliers. Such items normally are subject to longer delivery times. Special order items may carry cancellation charges once an order is placed and may also be subject to a restricted return policy.

V PROPER LAW AND JURISDICTION

The contract of sale and the respective rights and obligations of the Buyers and CLA-VAL Europe with regard thereto shall be governed by and construed according the laws of Switzerland. **The jurisdiction place is Lausanne (Switzerland).**

The implementation of the UN agreement on contracts for international sale of goods of 11 April 1980 (Viennese right to purchase) is expressly excluded.



SWITZERLAND

Europe, Middle East & Africa
Chemin des Mésanges 1
CH-1032 Romanel-sur-Lausanne
☎ + 41 21 643 15 55

UAE - DUBAI

Office 2004 , JBC5 - Cluster W - JLT
P.O. Box 336812 Dubaï, UAE
☎ +971 4 5667665

USA

Global Headquarters
1701 Placentia Avenue, Costa Mesa
CA 92627-4475
☎ + 949 722 4800

UNITED KINGDOM

Dainton House, Goods Station Road
CGB - Tunbridge Wells
Kent TN11 2 DH England
☎ + 44 1892 514 400

FRANCE

ZAC du Champ du Périer
1, Porte du Grand Lyon
FR - 01700 Neyron
☎ + 33 4 72 25 92 93

CANADA

4687 Christie Drive
Beamsville, Ontario
Canada L0R 1B4
☎ + 905 563-4963

NEW ZEALAND

45 Kennaway Road
1 Woolston, Christchurch, 8023
☎ + 64 396 44860

MEXICO

TubriValco, S.A. de C.V.
Circunvalacion Jorge Alvarez
del Castillo No 1206-3
Col. Chapultepec Country
CP 44620 - Guadalajara, Jalisco
☎ + (33) 11309329



WWW.CLA-VAL.CH